

Super Chipmunk

3D Printed R/C Aircraft

Build Guide

Wingspan: 1625mm (64")

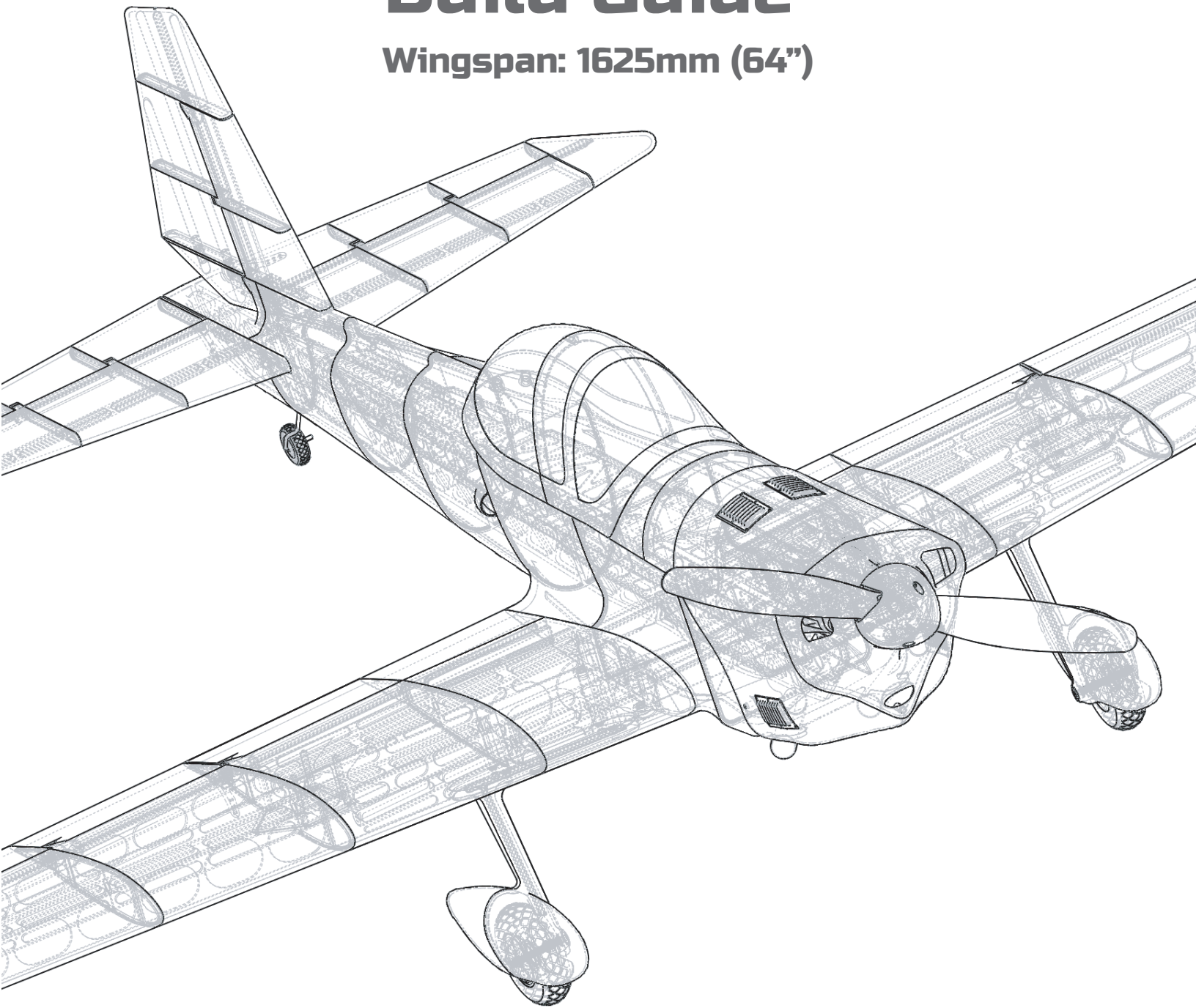

www.3DAeroventures.com

Included in Your Download:

1. STL Files
2. Simplify3D Factory Files (for the recommended materials)
3. Recommended Slicer Settings for different materials(Excel and PDF format)
4. Generic Gcode for i3 style printers (for the recommended materials)
5. PDF Build Guide

Please Read A Note from the Designer:

First of all, thank you so much for your interest and support of 3DAeroventures. I can't tell you how much joy I get out of designing and testing these aircraft, and the fact that you can now get joy out of my creations just makes this calling that much more special. I dove into the R/C aircraft hobby as a 12 year old kid with my dad and it's a passion I've maintained into adulthood. Part of 3DAeroventures mission is to encourage people to not let go of the thing they were most passionate about growing up. That's why our motto is "Never Stop Exploring. Never Stop Questioning. Never Stop Playing." I hope the building and flying of this model keeps your passion for model aviation ignited. More importantly, I encourage you to share your build and flying process with young people, hopefully igniting a fire in them and helping to maintain and grow this wonderful hobby.

Now, on to the technical stuff. I haven't been very happy with single wall 3D printed aircraft, and after playing with so many different materials I am now a big proponent of using multiple material types to build a good performing and long-lasting craft. So I've totally changed my design methodology for these planes to meet a few goals: Better printability/surface quality, Increased part strength, the ability to print the parts in any material - PLA, ABS, ASA, PETG, and especially LW-PLA or LW-ASA, much simpler slicing and the ability to use any slicer (like Prusa Slicer), and lower my design time so I can release more designs each year.

I've accomplished those goals with the design of this Super Chipmunk. The outer walls of the parts now print like a corrugated plastic - two single perimeter walls filled with a very low infill, anywhere between 3 - 7%. The downside is, printing this style of design in standard PLA leads to a heavy aircraft, though not too heavy to fly well. That's why I am particularly excited about the results I've gotten printing this aircraft as a hybrid with LW-PLA. My first prototype is printed in PLA and the fully-loaded flying weight, painted, came in over 4600 grams. It flies great with my recommended Leopard motor on a 6S. But contrast that to my final prototype, printed as a hybrid LW-PLA version, which came out to 3300 grams, painted. I highly recommend printing this design in a lighter plastic like ABS/ASA or a combination of LW-PLA and PLA.

I'd love to hear about your build and flight experience with this aircraft. You may contact me directly at eric@3daeroventures.com with any feedback or troubleshooting questions. Or post your experiences on the [3DAeroventures Pilots Alliance](#) Facebook Group.

Thanks again and enjoy your flight!

Eric Haddad
Pilot in Command



www.3DAeroventures.com

Specs:

Scale:	1/6 Scale
Wingspan:	1625mm / 64"
Length:	1356mm / 53.4"
Height:	482mm / 19"
Wing Area:	704 in ²
Wing Loading (LW-PLA Hybrid):	23.4 oz/ft ²
Wing Cube Loading (LW-PLA Hybrid):	10.6
Wing Loading (PLA):	30.7 oz/ft ²
Wing Cube Loading (PLA):	13.9
Flight Performance Category:	Scale Aerobatics
Center of Gravity Location:	75 - 85mm behind the Wing's Leading Edge
Weight of Printed Parts (LW-PLA Hybrid):	1938g / 68.4 oz
Weight of Printed Parts (PLA):	2817g / 99.4 oz
Flying Weight :	3250g (LW-PLA) to 4250g (PLA) / 114.6 - 149.9 oz
Recommended Max Flying Weight:	4500g / 158.7 oz
No. of Channels:	4 - Throttle, Aileron, Elevator, Rudder

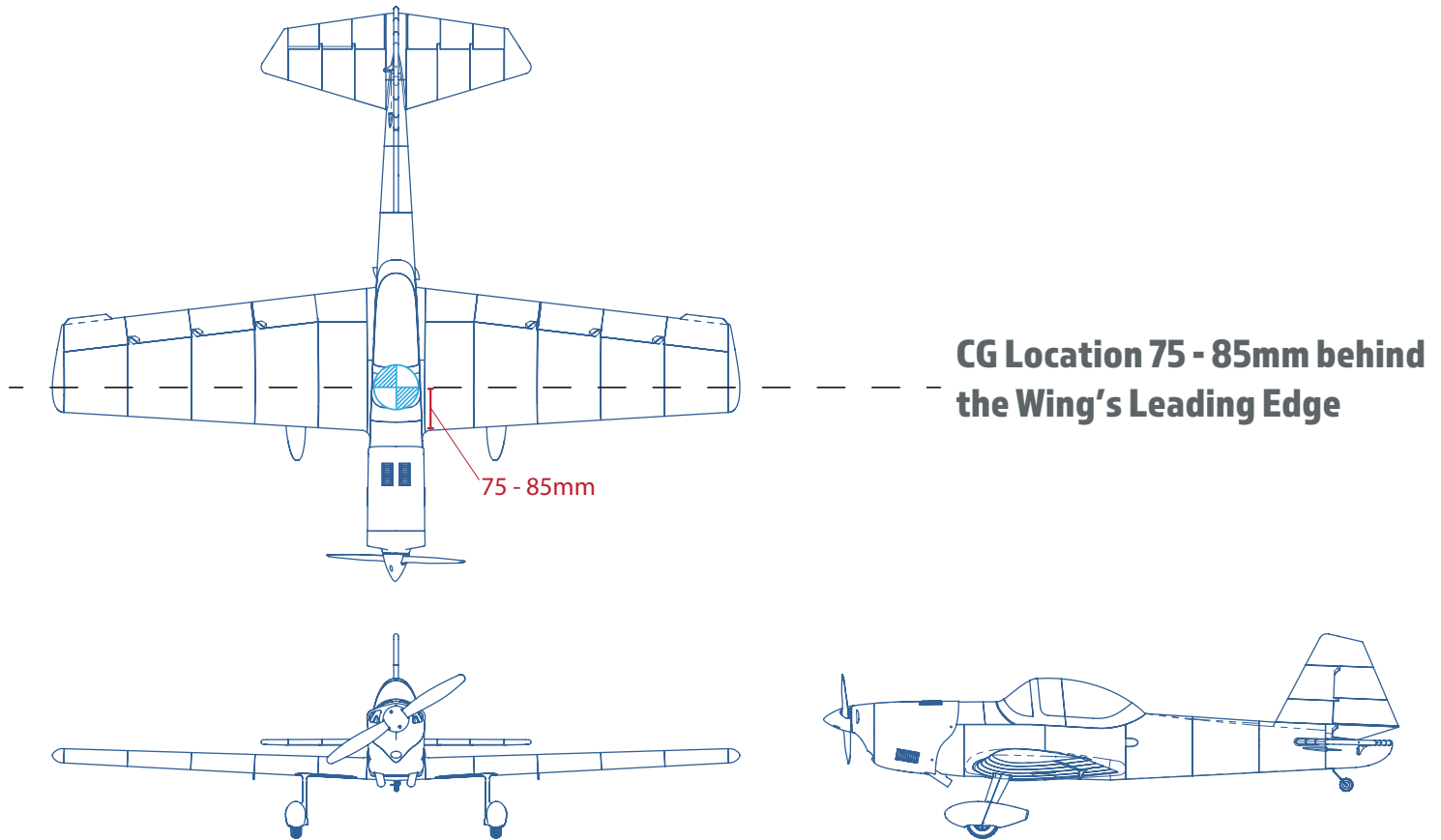

www.3DAeroventures.com

Recommended Setup:

- Motor Options:** [Leopard 5065-7T - 380kV](#)
[Leopard 5055-10T - 390kV](#)
[Turnigy Aerodrive SK3 5055-430kV](#)
or motor with equivalent mounting pattern
- ESC Options:** 80A Esc like [Hobbywing Skywalker Series 80A ESC](#)
- Rec. Prop Size:** [15x8 to 16x10 \(follow your motor's recommendations within this range\)](#)
- Battery:** [6S 5000 mAh LiPo \(PLA, ABS/ASA, or PETG version\)](#)
[5S 5000mAh LiPo \(LW-PLA Hybrid version\)](#)
- Radio:** [Radio + 4ch - 6ch Receiver](#)
- Servos:** [EMAX ES3004](#) or [EMAX ES3054](#) or equivalent size servo (x4)
[EMAX ES-3005](#) or [Flite Test ES3005](#) or equivalent size servo (x1)
[Y Harness](#) for aileron and elevator servos (optional)
- We recommend using a 6 channel receiver to mix servos instead of using a Y Harness

Tools and Materials Needed:

- Min 200mm x 200mm x 200mm desktop 3D Printer
- ColorFabb LW-PLA or LW-ASA (Recommended)
- High Quality Standard PLA, ABS, ASA, or PETG
- TPU or TPE for Tires
- Medium Bodied CA/Super Glue
- Accelerator for CA
- Two-Part Epoxy Adhesive - 5-minute cure time
- Sandpaper and/or Small Files
- Spray Paint or Airbrush Paints
- Velcro strips with adhesive backing
- Screwdriver and/or allen wrench for chosen screws/bolts
- Needle Nose Pliers
- Dremel/Rotary Tool for cutting carbon fiber tubes



www.3DAeroventures.com

Hardware Needed:

Quantity:

- **M3 x 0.5mm Thread x 12mm Long Screws** for Cowling and Landing Gear..... 12
- **M3 x 0.5mm Thread x 25mm Long Screws** for Spinner..... 2
- **M4 x 0.7mm Thread x 16mm Long Screws** for Motor Mount and Wing Mount..... 12
- **M5 x 0.8mm Thread x 40mm Long Screws** for Landing Gear..... 2
- **M3 x 0.5mm Thread Lock Nut** for Spinner..... 2
- **M3 x 0.5mm Thread Heat-Set Threaded Inserts** for Cowling and Landing Gear..... 12
- **M4 x 0.7mm Thread Lock Nut** for Motor Mount..... 8
- **M4 x 0.7mm Thread Heat-Set Threaded Inserts** for Wing Mounts..... 4
- **M5 x 0.8mm Thread Lock Nut** for Landing Gear..... 2
- **Steel washer for M5 Screw Size** for Landing Gear..... 2
- **M2 or #2 Thread Forming or Tapping Screws** for mounting servo covers..... 8
- **3mm O.D. (or 1/8" O.D) x 10mm Long Dowel Pins** (cut from scrap carbon tube/rod)..... 9
- **10mm O.D. Carbon Fiber Tubes** 600mm (or 24") Long for Wing Roots..... 2
- **6mm O.D. Carbon Fiber Tubes**
 - 600mm (or 24") Long for Wing Tips (x2)..... 2
 - 500mm Long for Horizontal Stab..... 1
 - 220mm Long for Vertical Stab..... 2
- **1mm - 1.5mm O.D. Carbon fiber rod or Steel Wire**
 - 650mm Long for Aileron Hinges (x2)..... 2
 - 550mm Long for Elevator Hinge..... 1
 - 220mm Long for Rudder Hinge..... 1
- **2mm (or 2-56) diameter steel wire with threaded ends for servo control rods**
 - **30" for elevator and rudder**..... 3
 - **12" for ailerons**..... 2
- **4mm O.D. x 20 - 25mm Long Compression Spring** for Canopy Latch..... 1
 - **Note: The spring from a click pen or mechanical pencil will work**
- **1.8mm - 2mm diameter steel wire** for tailwheel wire..... 1
- **Nylon or Steel Kwik-Links**..... 5
- **Adjustable Pushrod Connectors** (optional)..... 3
- **Wheel Collars to fit 5mm rod** (main landing gear)..... 2
- **Wheel Collar to fit 2mm rod** (tailwheel)..... 1
- **4" servo extensions** for aileron servos..... 2
- **6" servo extensions** for aileron ports in receiver..... 2



www.3DAeroventures.com

Estimated Part Weights by Material Type (Grams):

Part Name	Hybrid PLA/LW-PLA Weights	Recommended Material for Hybrid	Estimated PLA/PETG Weights	Estimated ABS/ASA Weights
Fuse 1	78	LW-PLA	149	126
Fuse 2	137	PLA	137	149
Fuse 3	134	PLA	134	112
Fuse 4	43	LW-PLA	81	71
Fuse 5	40	LW-PLA	74	65
Fuse 6	38	LW-PLA	71	62
Fuse 7	28	LW-PLA	59	52
Fuse Tray 1	20	PLA	20	18
Fuse Tray 2	28	PLA	28	25
Fuse Tray 3	18	PLA	18	16
Fuse Tray 4	16	PLA	16	14
Fuse Tray 5	10	PLA	10	9
Wing R1	100	PLA	100	88
Wing R2	56	LW-PLA	103	91
Wing R3	48	LW-PLA	86	76
Wing R4	43	LW-PLA	81	71
Wing R5	35	LW-PLA	65	57
Wing L1	100	PLA	100	88
Wing L2	56	LW-PLA	103	91
Wing L3	48	LW-PLA	86	76
Wing L4	43	LW-PLA	81	71
Wing L5	35	LW-PLA	65	57
Wing Trailing Edge R	13	LW-PLA	23	20
Wing Trailing Edge L	13	LW-PLA	23	20
Wing Tip R	8	LW-PLA	16	14
Wing Tip L	8	LW-PLA	16	14
Wing Servo Covers	15	PLA	15	15
Aileron R1	14	LW-PLA	24	21
Aileron R2	14	LW-PLA	24	21
Aileron R3	14	LW-PLA	24	21
Aileron R4	14	LW-PLA	24	21
Aileron L1	14	LW-PLA	24	21
Aileron L2	14	LW-PLA	24	21
Aileron L3	14	LW-PLA	24	21
Aileron L4	14	LW-PLA	24	21
Canopy 1	12	LW-PLA	25	22
Canopy 2	30	LW-PLA	56	49
Canopy 3	32	LW-PLA	60	53
Cowl 1	14	LW-PLA	32	38
Cowl 2	90	PLA	90	90
Elev R1	8	LW-PLA	17	15
Elev R2	8	LW-PLA	13	11
Elev R3	6	LW-PLA	11	10
Elev R4	6	LW-PLA	14	12
Elev L1	8	LW-PLA	17	15
Elev L2	8	LW-PLA	13	11
Elev L3	6	LW-PLA	11	10
Elev L4	6	LW-PLA	14	12
Horiz Stab R1	14	LW-PLA	27	24
Horiz Stab R2	13	LW-PLA	22	19
Horiz Stab R3	10	LW-PLA	19	17
Horiz Stab L1	14	LW-PLA	27	24
Horiz Stab L2	13	LW-PLA	22	19
Horiz Stab L3	10	LW-PLA	19	17
Landing Gear R1	41	PLA	41	36
Landing Gear R2	43	PLA	43	40
Landing Gear L1	41	PLA	41	36
Landing Gear L2	43	PLA	43	40
Motor Mount	65	ABS, ASA, or PETG	65 (PETG)	57
Rudder 1	6	LW-PLA	13	11
Rudder 2	12	LW-PLA	22	19
Rudder 3	11	LW-PLA	19	17
Rudder 4	13	LW-PLA	22	19
Vert Stab 1	10	LW-PLA	17	15
Vert Stab 2	11	LW-PLA	19	17
Control Horns	11	PLA, ABS, ASA, or PETG	11	11
Printed Part Weight	1938		2817	2507

OPTIONAL PARTS	Estimated Weights	Recommended Material
Tire	20	TPU/TPE
Tire Hub 1	7	PLA, ABS, ASA, or PETG
Tire Hub 2	7	PLA, ABS, ASA, or PETG
Tailwheel Tire	2	TPU/TPE
Tailwheel Hub 1	1	PLA, ABS, ASA, or PETG
Tailwheel Hub 2	1	PLA, ABS, ASA, or PETG
Spinner 1	25	PLA, ABS, ASA, or PETG
Spinner 2	9	PLA, ABS, ASA, or PETG

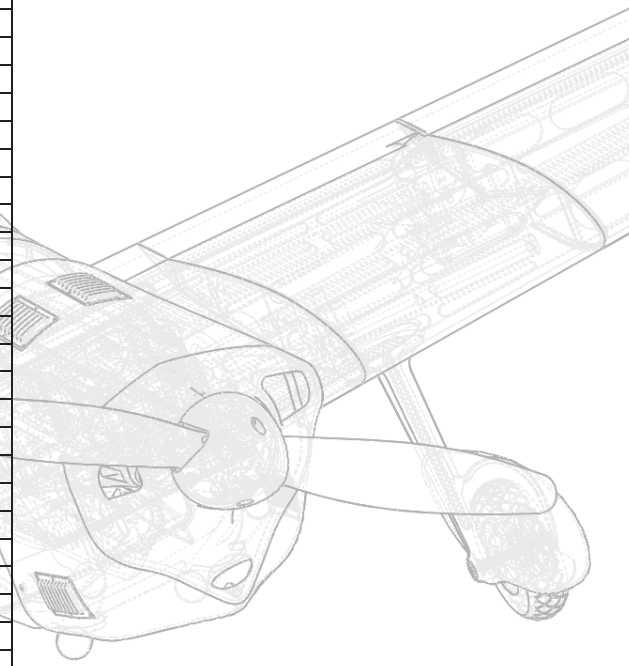

Step-by-Step Build Guide

Step 1. 3D Printing the Included Parts

Minimum Requirements:

200mm x 200mm x 200mm Print Bed Size

0.4mm Nozzle

Heated Bed (recommended)

Any Slicer Software

Your Options for Printing the Parts:

Option 1: G-Code

Transfer the included G-Code to an SD Card and run directly on your i3 style printer using the materials we recommend. The provided G-Code is for our recommended PLA / LW-PLA Hybrid build. We've had good results with LW-PLA at 250° Celcius and standard PLA at 225° Celcius but experiment with your printer to make sure you achieve strong layer adhesion. If you wish to print this aircraft from a different material, reference the included Slicer Settings PDF and use your preferred slicer.

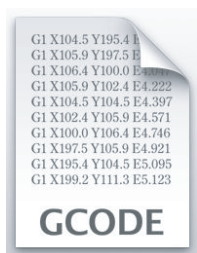

Option 2: Simplify 3D Factory Files

If you prefer to use Simplify3D as your slicer, open the included Factory Files and edit the preset profiles for your printer/material to ensure nice outer surfaces and excellent layer bonding.



Option 3: STL + Your Preferred Slicer

If you prefer to use another slicer or create your own profiles in Simplify3D, use the included STL files and reference the included Recommended Slicer Settings PDF.



www.3DAeroventures.com

Step-by-Step Build Guide (cont'd)

3D Printing Tips



ColorFabb LW-PLA

ColorFabb LW-PLA is an interesting material that uses foaming technology to achieve lightweight, low density PLA parts. This material is printed at a higher temperature (which causes it to expand) and a much lower extrusion multiplier than standard PLA. In order to determine the proper nozzle temperature and extrusion multiplier for your particular printer you can follow ColorFabb's instructions: <https://learn.colorfabb.com/print-lw-pla/>

We had good results printing LW-PLA at 250°C at an Extrusion Multiplier of 0.4 and a bed temp of 60°C. You will also likely combat quite a bit of stringing with LW-PLA. We increase X/Y Axis Movement Speed to 200mm/s and run the cooling fan at 25% to help combat stringing.

Standard PLA Temperatures:

We see good results printing Paramount3D PLA at 225°C with a bed temperature of 70°C. Experiment with your particular printer and brand of material to ensure proper layer bonding but you will likely land somewhere between 210 and 240°C.



Cooling Fan:

Typically, PLA is printed with the fan set to 100%. However, this can cause layer bonding issues when printing thin walled aircraft. We have experienced nice, clean outer surfaces when keeping the fan speed up to 20% without negatively affecting layer bonding. Experiment with fan speeds set between 0 - 20%.

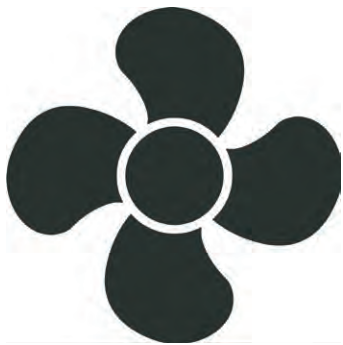

www.3DAeroventures.com

Step-by-Step Build Guide (cont'd)

3D Printing Tips (cont'd)

Standard Materials Extrusion Multiplier (Flow):

You will need to experiment with extrusion multiplier for your particular printer and material. You will likely land somewhere between 0.95 and 1.05 extrusion multiplier.

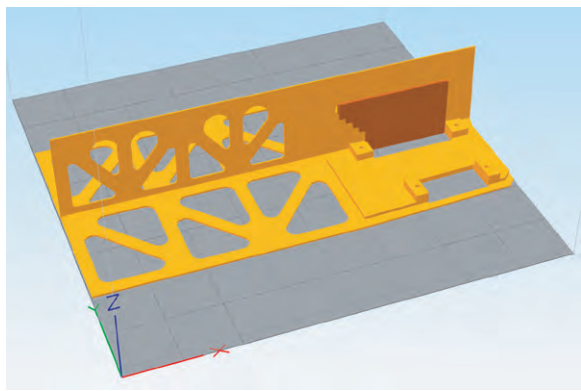

Support Structures:

The "Fuse Tray 3" part of this aircraft requires support structures and it's recommended to use your slicer's auto-generated support structures. The GCode and the Simplify3D Factory Files already have the support structures in place.

Elephant's Foot:

Try to avoid the first few layers of each print from squishing too far outside the designed wall dimensions, also known as "elephant's foot". This can be caused by your nozzle being too close to the print bed or first layer width set too high in your slicer. A small amount of elephant's foot is okay but too much will interfere with the designed alignment aids.

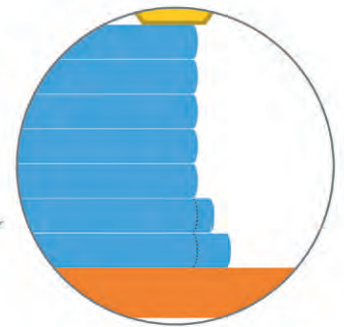

www.3DAeroventures.com

Step-by-Step Build Guide (cont'd)

Step 2. Fuselage Assembly

Tools and Materials Needed:

- Medium Bodied CA/Super Glue
- Accelerator for CA
- Two-Part Epoxy Adhesive - 5-minute cure time
- Sandpaper and/or Small Files
- Hobby Knife
- Needle Nose Pliers for bending tailwheel wire

Hardware Needed (links to recommended hardware on pg 5):

- 4mm O.D. x 20 - 25mm Long Compression Spring (from a click pen or mechanical pencil)
- 3mm O.D. (or 1/8" O.D) x 10mm Long Dowel Pins (cut from scrap carbon tube/rod) (x3)
- M3 x 0.5mm Thread Heat-Set Threaded Inserts for Cowling (x4)
- M4 x 0.7mm Thread Heat-Set Threaded Inserts for Wing Mounts
- M4 x 0.7mm Thread Lock Nut for Motor Mount (x4)
- 1.8mm - 2mm diameter steel wire for tailwheel wire

Printed Parts Needed:

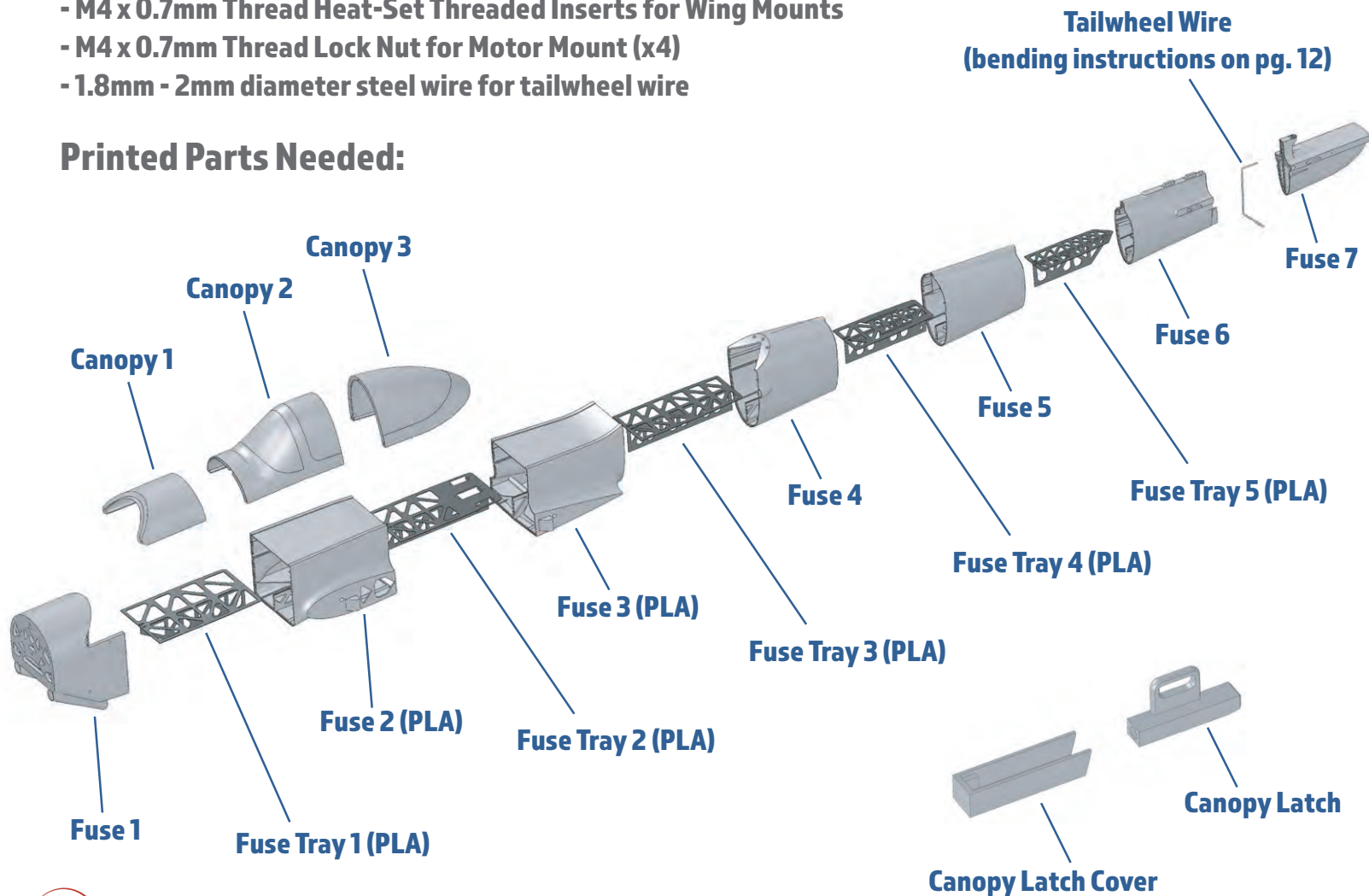

www.3DAeroventures.com

Step-by-Step Build Guide (cont'd)

Step 2.1 Bend the Tailwheel Wire to Shape

ATTENTION: Do not glue Fuse 7 into place without the tailwheel wire set in place between Fuse 6 and Fuse 7. Print out the drawing of the tailwheel wire on the following page to aid in bending a 1.8mm - 2mm diameter steel wire to the proper shape. Set aside for a later step.

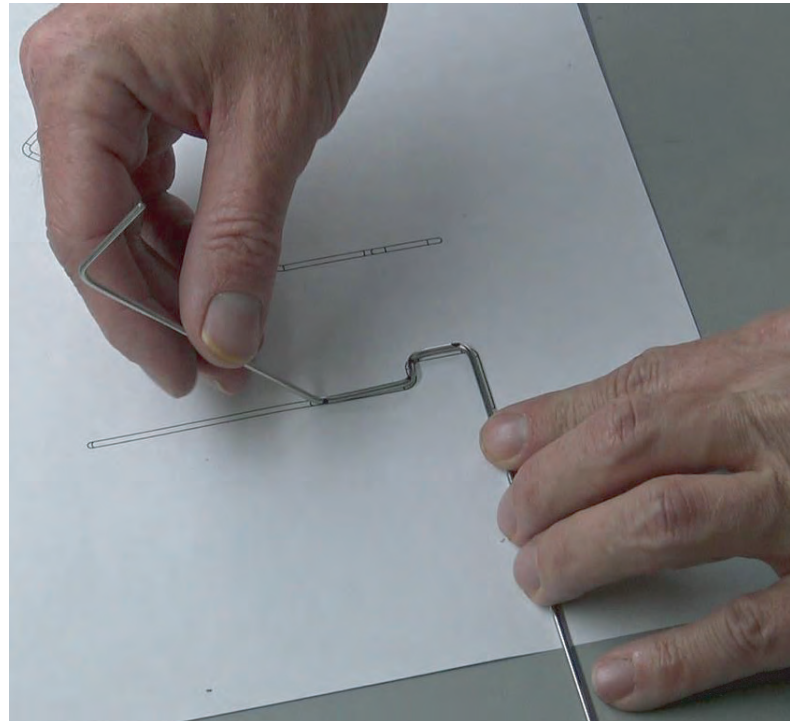
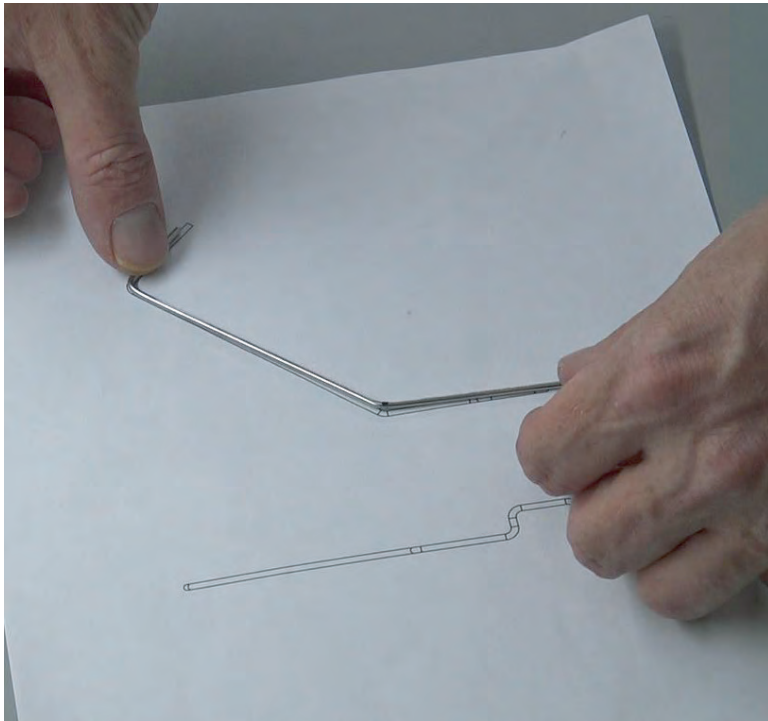

www.3DAeroventures.com

Tailwheel Wire
1.8mm - 2mm Diameter Wire

Scale 1:1

Front View

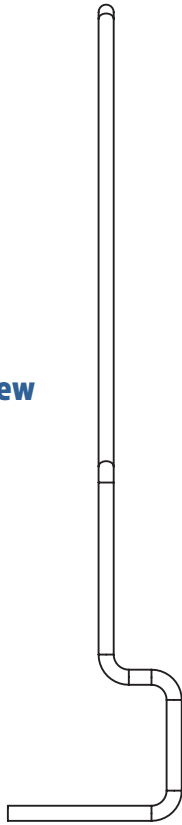

Side View

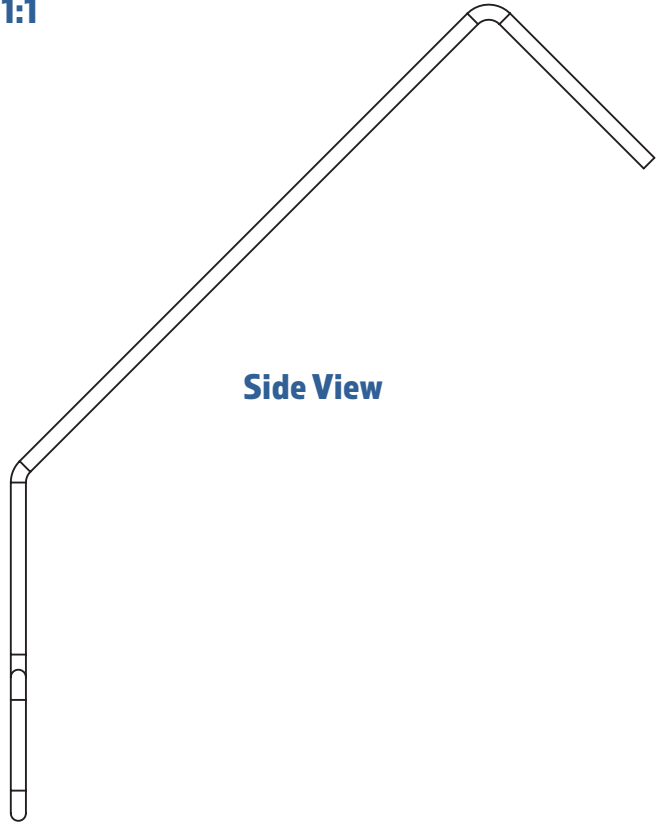

www.3DAeroventures.com

Step-by-Step Build Guide (cont'd)

Step 2.2 Glue Motor Mount Locknuts in Place

Use the two-part epoxy resin to permanently glue the qty. 4, M4 x 0.7mm Thread Lock Nuts in place in the hex-shaped recesses behind the firewall of Fuse 1.

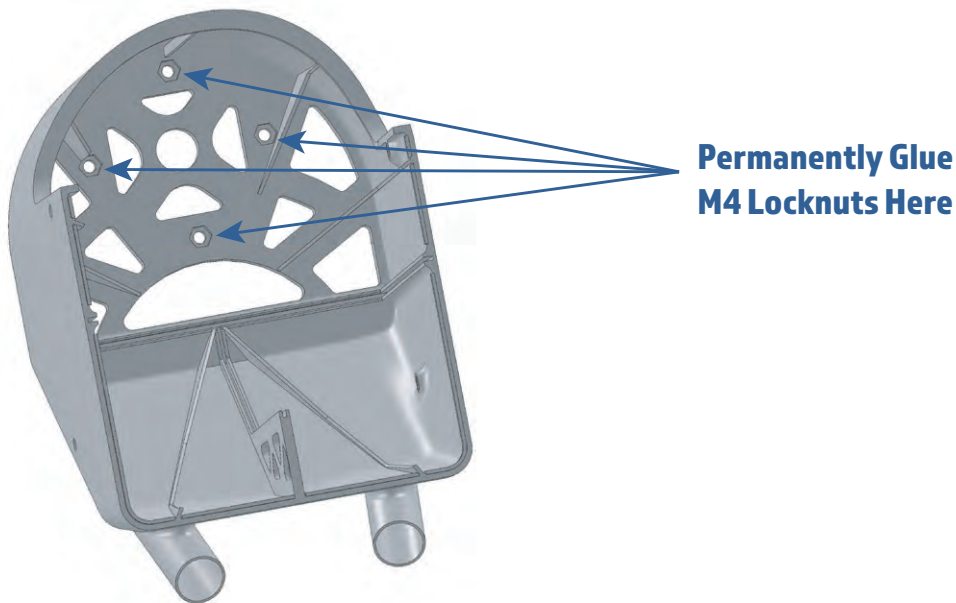

Step 2.3 Heat Set Inserts for Cowling and Wing Mounts

2.3.1 Once the epoxy has dried, use a soldering iron to sink qty. 4, M3 x 0.5mm Thread Heat-Set Inserts in place in the cowl mounting holes, which are located on the sides of Fuse 1.

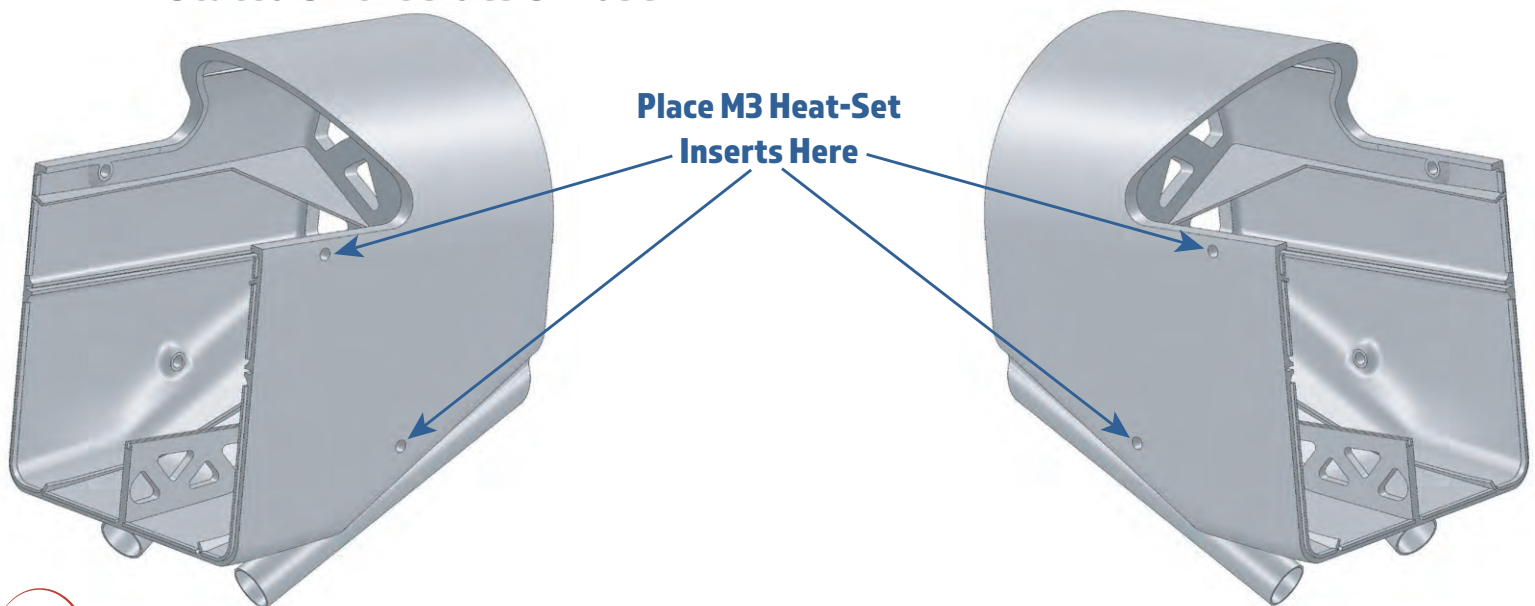

www.3DAeroventures.com

Step-by-Step Build Guide (cont'd)

2.3.2 Use the soldering iron to sink qty. 4, M4 x 0.7mm Thread Heat Set Inserts in place in the wing mounting holes, which are located on the sides of Fuse 2 and Fuse 3.

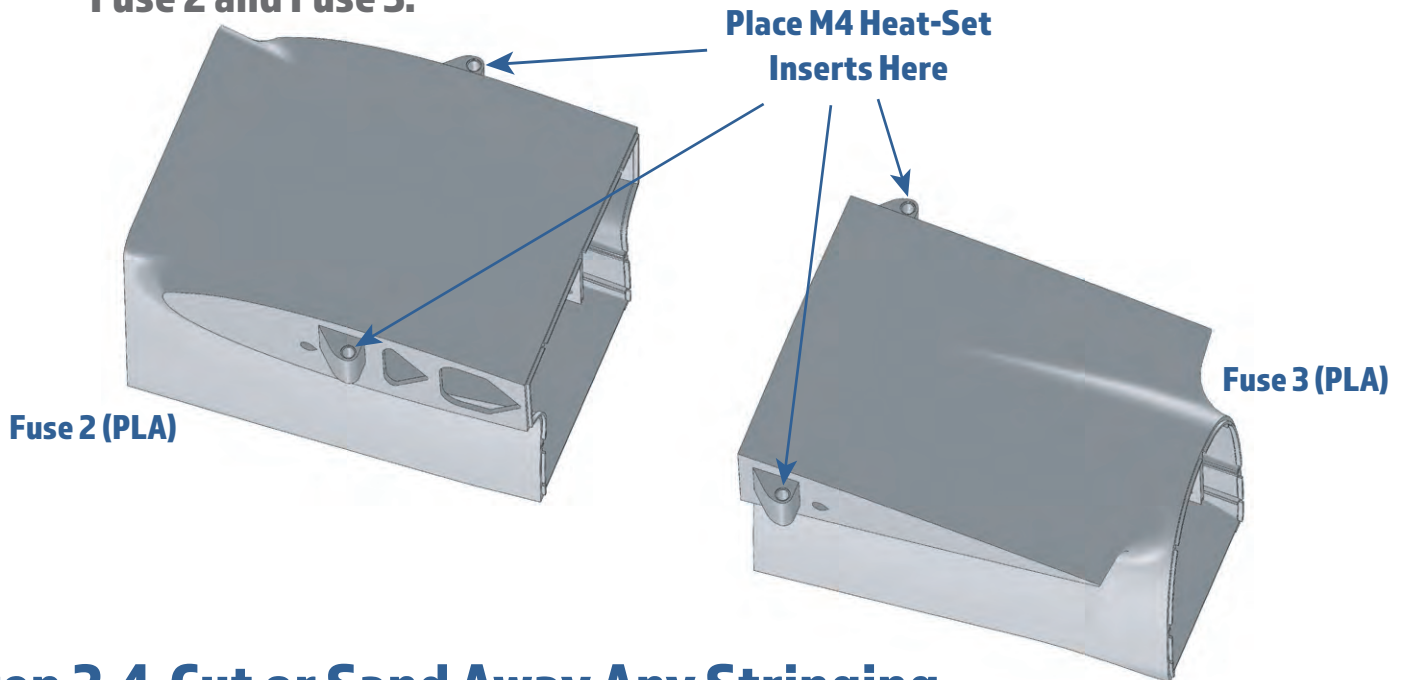

Step 2.4 Cut or Sand Away Any Stringing

When printing with LW-PLA you will likely have some residual stringing. Inspect all of the printed parts for stringing and use sand paper, a small file or a hobby knife to eliminate the stringing, especially in areas where parts will mate. You will find most of the stringing comes off quite easily.



www.3DAeroventures.com

Step-by-Step Build Guide (cont'd)

Step 2.5 Glue Fuselage and Fuse Tray Parts Together

ATTENTION: The fuselage is designed with separate Fuse Tray parts. This was done in case you choose to print the Fuse parts in LW-PLA or LW-ASA. The Fuse Tray parts should be printed in a more rigid plastic like standard PLA, ABS, PETG, or PC.

The Fuse parts must be assembled with the Fuse Tray parts in a certain order. You will notice the Fuse Tray parts slide into rails located in the Fuse parts. The Trays overlap the seams of the Fuse parts and make for a very strong, rigid fuselage.

**DO NOT GLUE ALL OF THE FUSE PARTS TOGETHER
WITHOUT THE FUSE TRAY PARTS IN PLACE!**



www.3DAeroventures.com

Step-by-Step Build Guide (cont'd)

Step 2.5 Glue Fuselage and Fuse Tray Parts Together (cont'd)

2.5.1 Starting with Fuse 1, apply CA adhesive to the rails where Fuse Tray 1 slides into place. **Ensure Fuse Tray 1 is fully seated into place in the rail behind the firewall and wipe off any residual glue from the Fuse 1 surface that mates with Fuse 2 before applying CA Accelerator to secure the bond.**

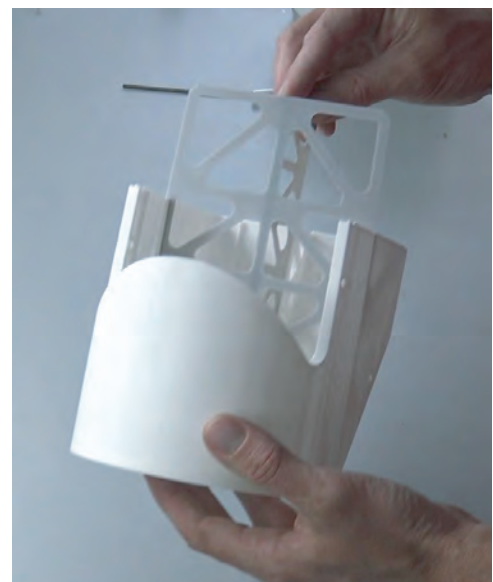
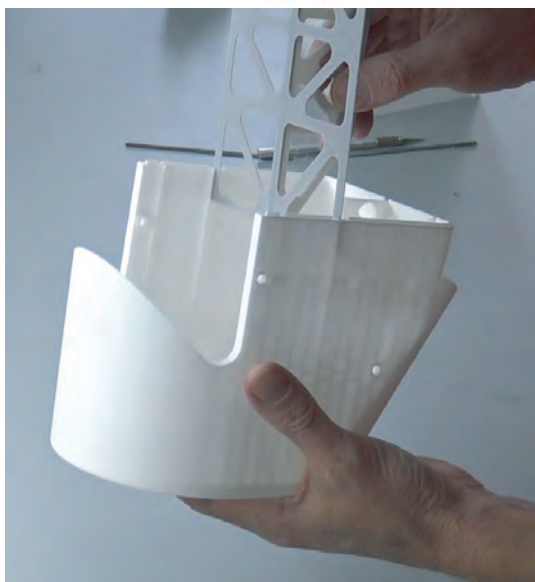
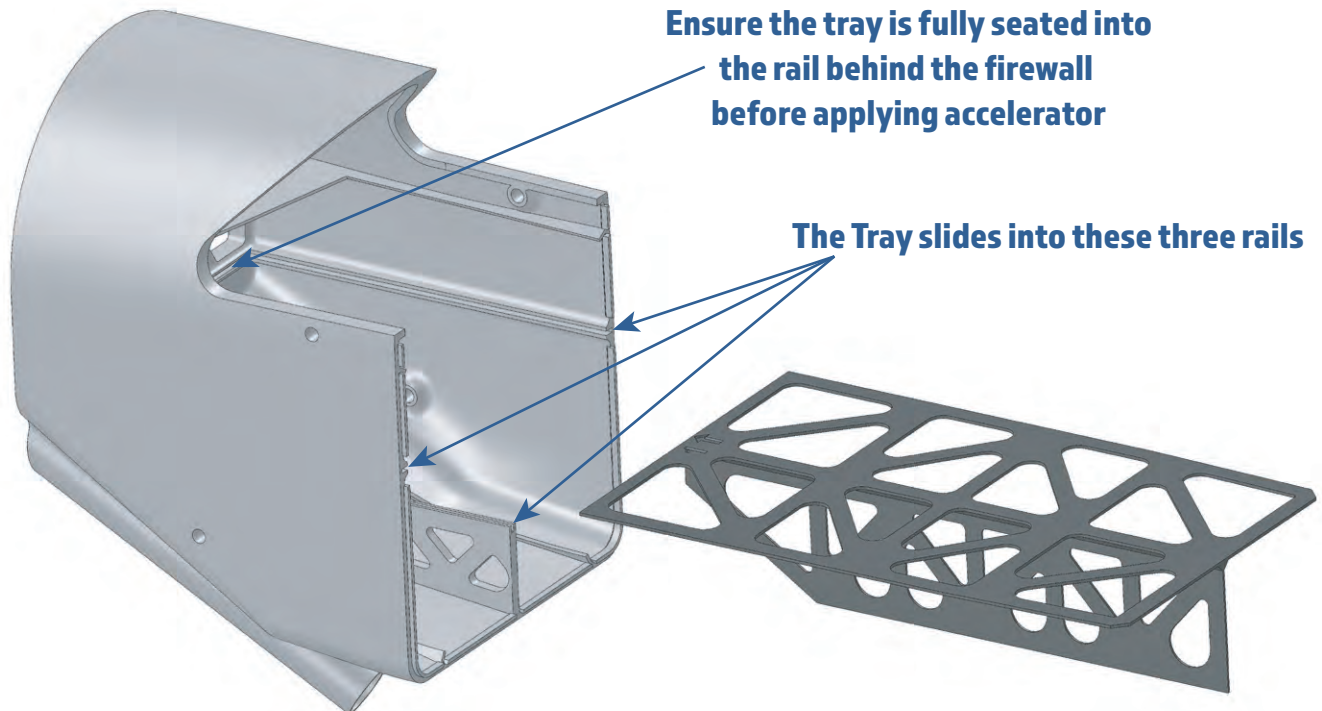

www.3DAeroventures.com

Step-by-Step Build Guide (cont'd)

2.5.2 Glue part Fuse 2 to the Fuse 1 sub-assembly. Make sure to apply the CA glue to the mating faces of Fuse 1 and Fuse 1 as well as the portions of Fuse Tray 1 that slide into the rails inside Fuse 2.

NOTE: Because of the stringing of LW-PLA you may need to clean up the alignment tabs and alignment holes with a hobby knife

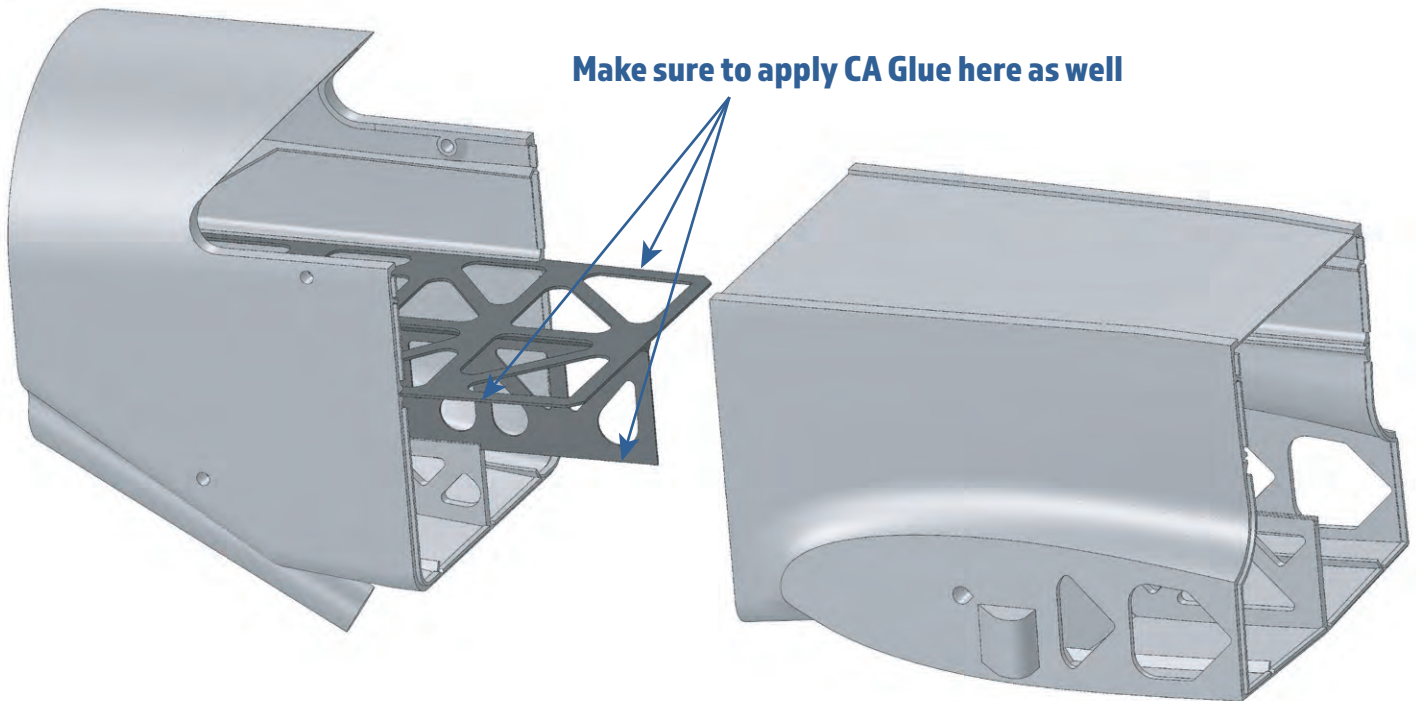

2.5.3 Now glue part Fuse Tray 2 into your assembly just as you did with Fuse Tray 1. Apply the CA glue to the rails inside Fuse 2 and slide Fuse Tray 2 in place until fully seated before applying accelerator.

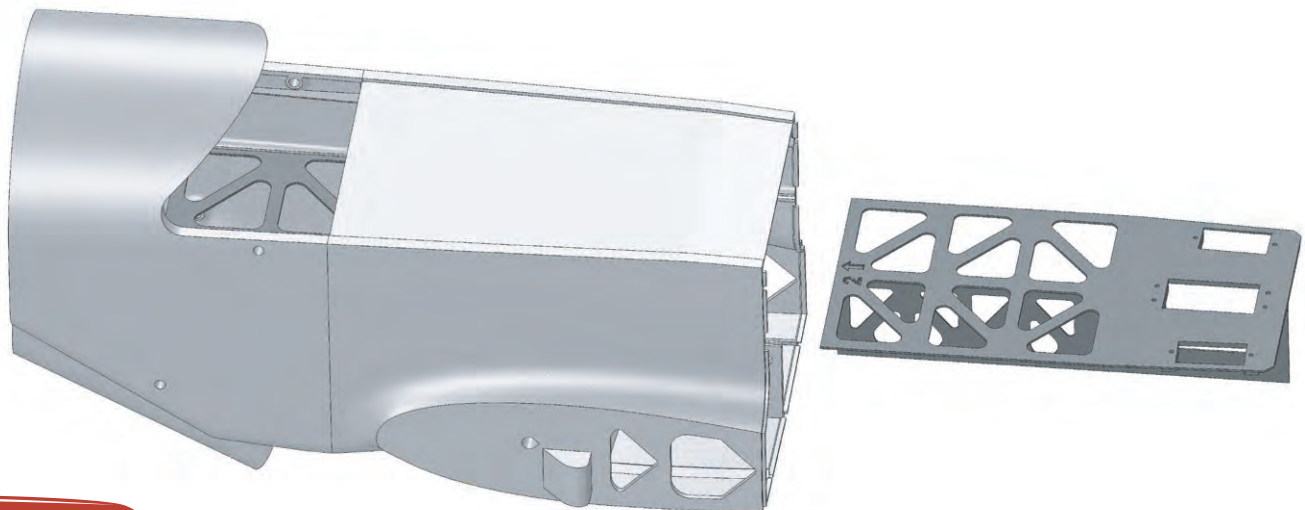

www.3DAeroventures.com

Step-by-Step Build Guide (cont'd)

2.5.4 Repeat Steps 2.5.2 and 2.5.3 for the remainder of the Fuse and Fuse Tray parts, following the order shown in the image below.

ATTENTION: Stop after gluing part Fuse 6 in place. Do not glue Fuse 7 into place without the tailwheel wire set between Fuse 6 and Fuse 7. Print out the drawing of the tailwheel wire on page 12 to aid in bending a 1.8mm - 2mm diameter steel wire to the proper shape.

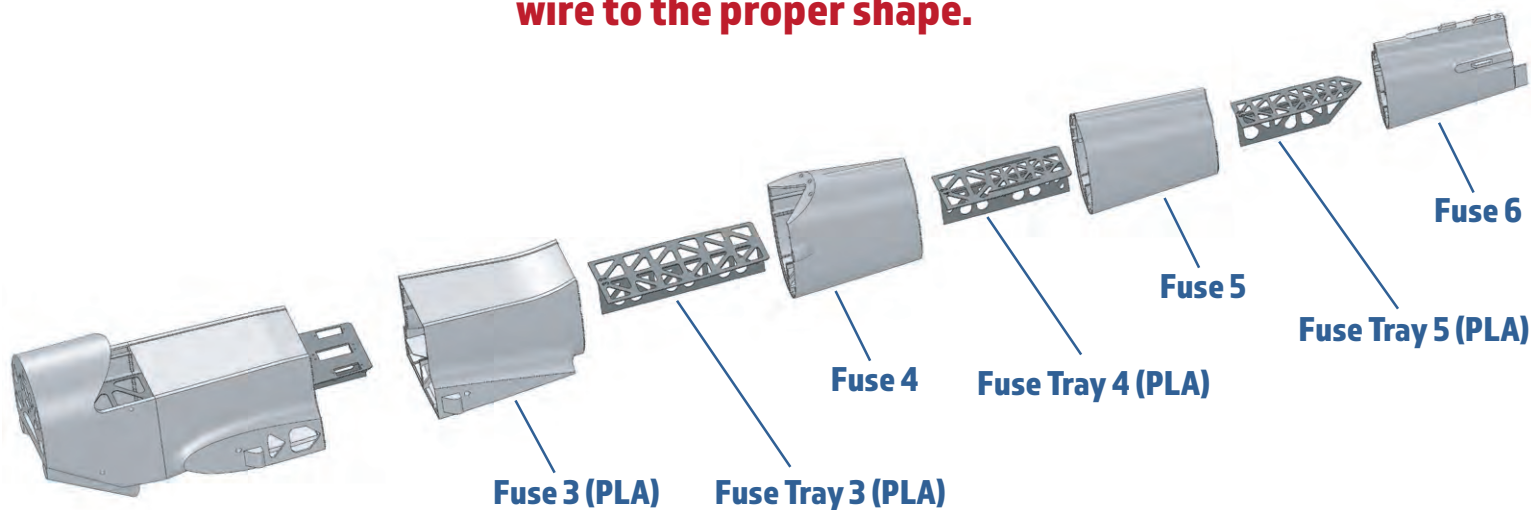

www.3DAeroventures.com

Step-by-Step Build Guide (cont'd)

2.5.5 Rest the bent tailwheel wire in place in Fuse 7 and glue Fuse 7 to Fuse 6, taking care not to get any adhesive on the tailwheel wire. Once assembled, the 90 degree bend that is at the top of the tailwheel wire should stick out the back as shown in the figures below. This is the portion of the wire that will engage with the rudder during final assembly.

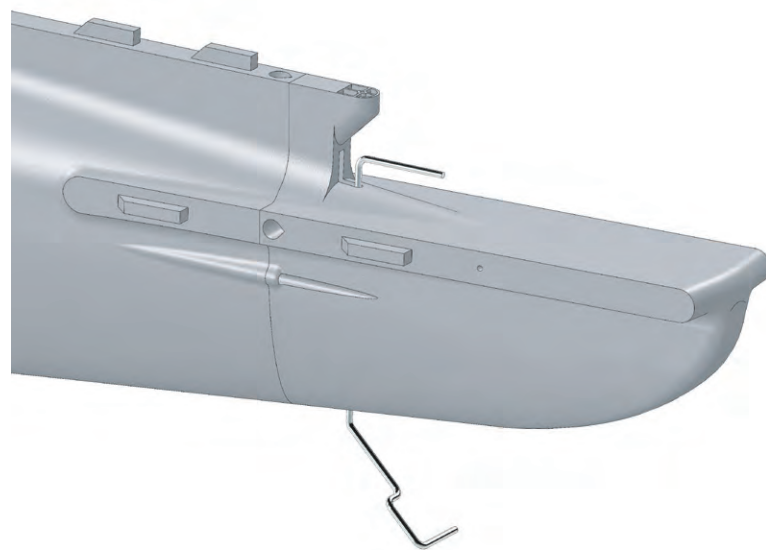
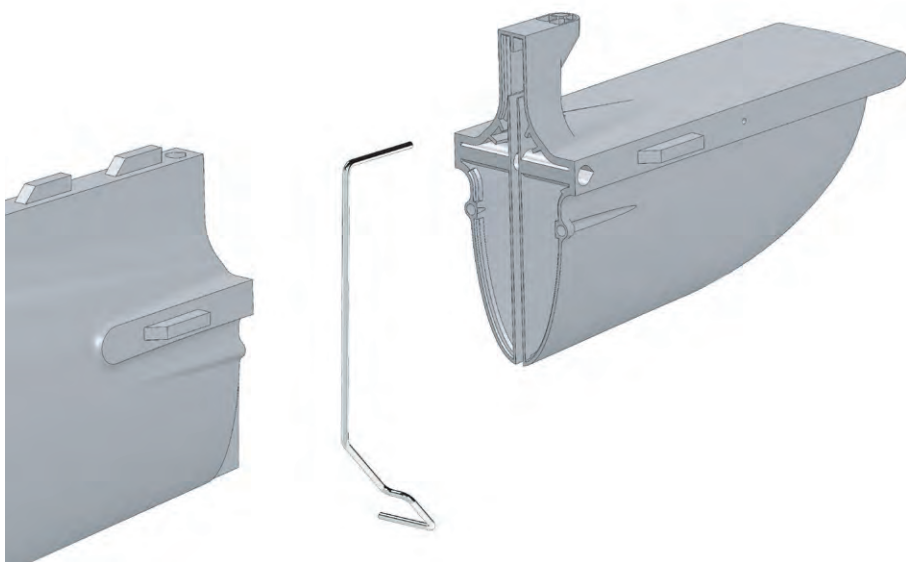

www.3DAeroventures.com

Step-by-Step Build Guide (cont'd)

2.5.6 Using a hot knife or soldering iron, follow the molded in line/guide to cut away the sacrificial support located on Fuse 2 and Fuse 3.

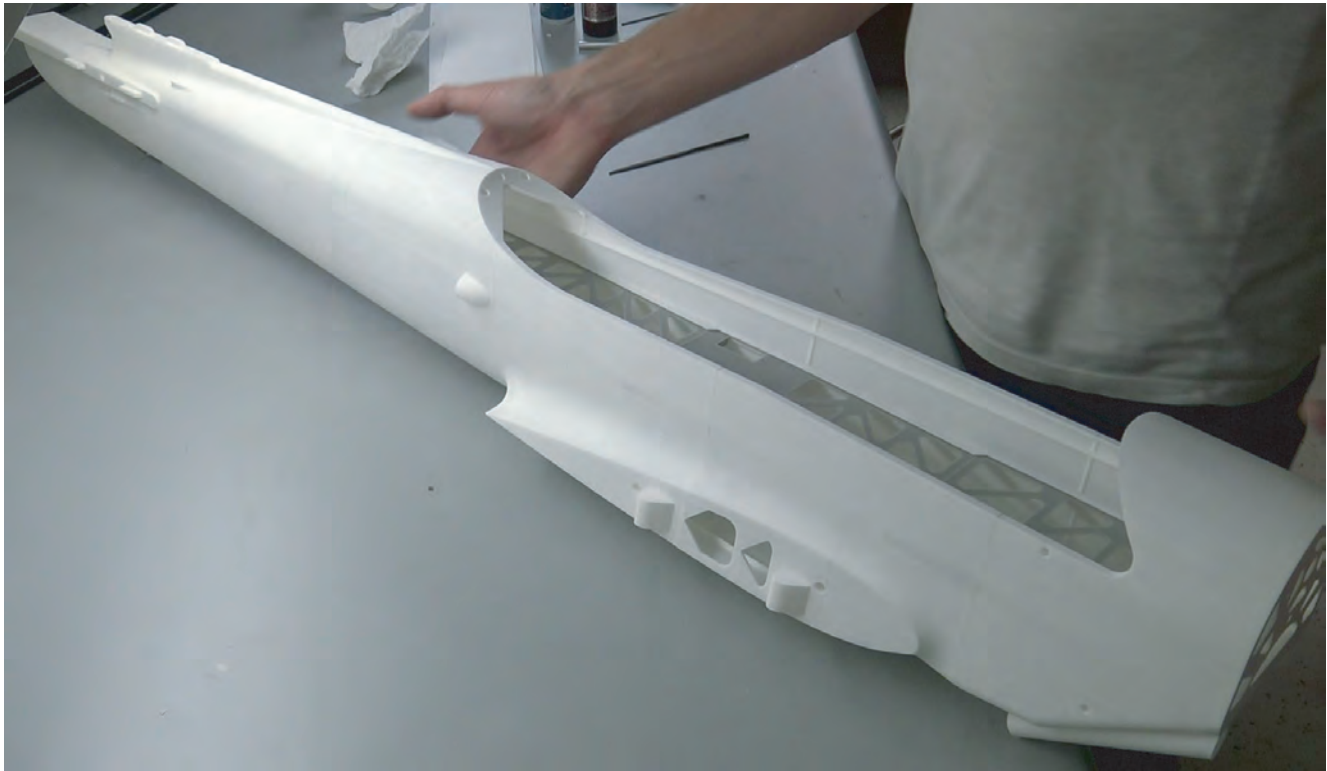

www.3DAeroventures.com

Step-by-Step Build Guide (cont'd)

Step 2.6 Glue Canopy Parts Together

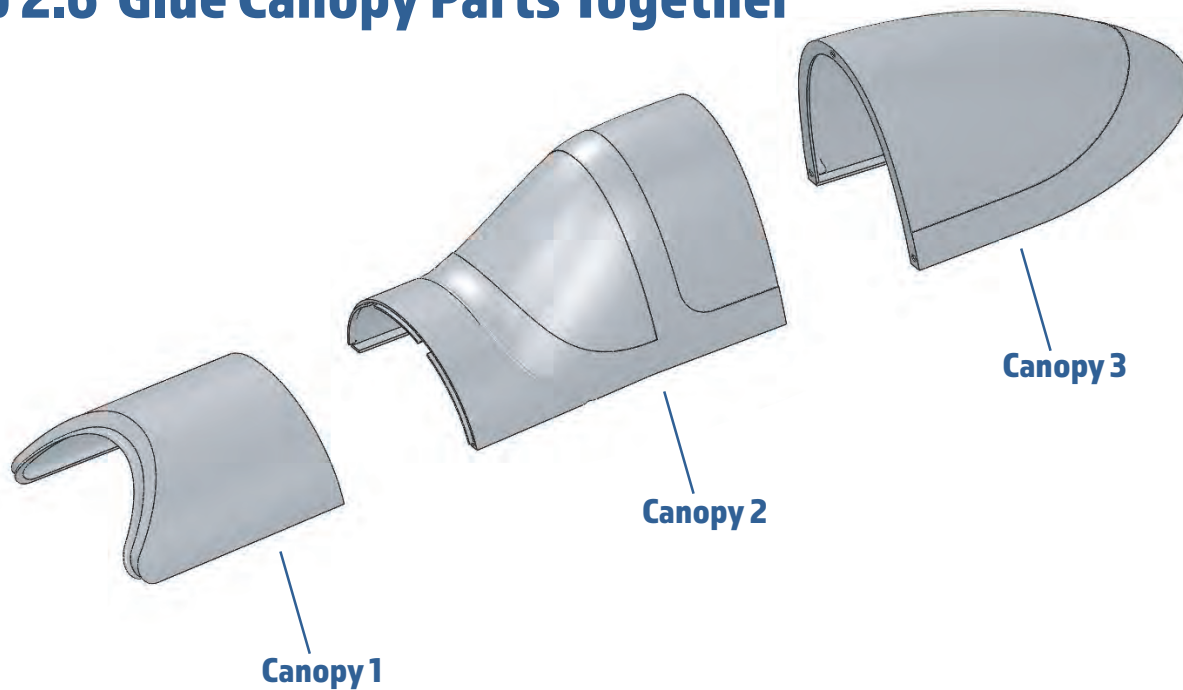

2.6.1 Glue parts Canopy 1 and Canopy 2 together, which include built-in alignment aids. Use qty. 3 , 3mm diameter x 10mm long dowel pins cut from scrap wood dowels or carbon fiber rods to align Canopy 3 to Canopy 2 and glue together. You may need to clear out the dowel pin holes with a 3mm or 1/8" drill bit.



www.3DAeroventures.com

Step-by-Step Build Guide (cont'd)

If you are painting your model, it is recommended to complete the following Canopy Latch steps AFTER painting the canopy.

2.3.6 The canopy is held in place with a spring loaded latch mechanism. The 4mm O.D. spring can be purchased from the link provided or pulled from a click pen or mechanical pencil. If needed, trim the spring to a length of 20 - 25mm.

2.3.7 Insert the Canopy Latch part into the slots located on the back of Canopy Hatch 3. Insert the spring into the hole located on the end of the Canopy Latch.

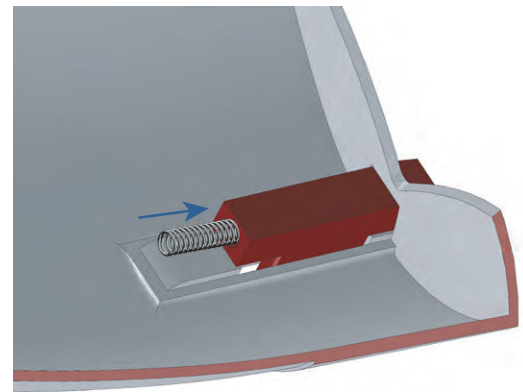
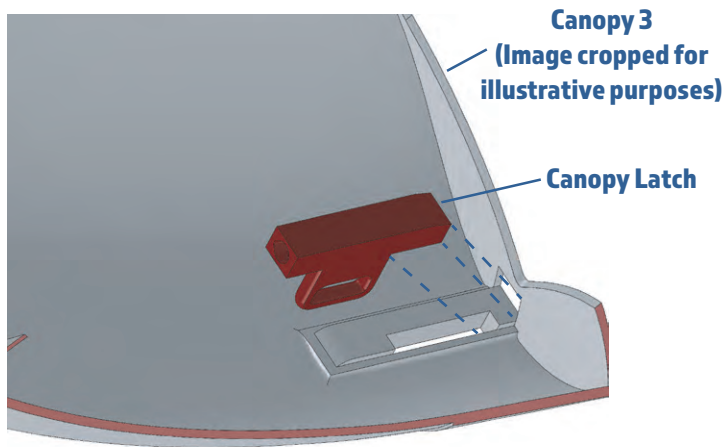

2.3.8 Glue the Canopy Latch Cover into place. You'll see a slot in the Canopy Latch Cover where the spring will insert. Ensure the Canopy Latch Cover is fully seated to the back of Canopy 3. This will keep the spring slightly compressed. **BE EXTRA CAREFUL NOT TO GLUE THE CANOPY LATCH PART IN PLACE AND IT IS FREE TO SLIDE BACK AND FORTH.**

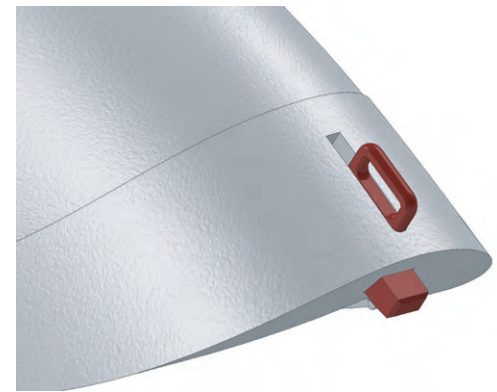
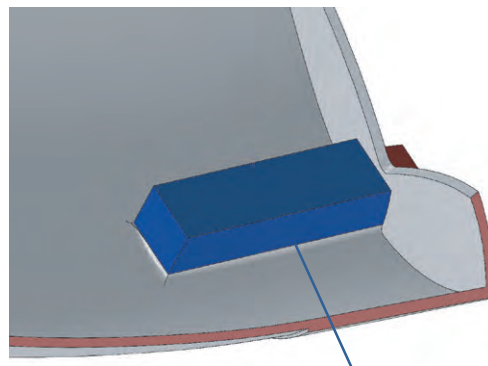
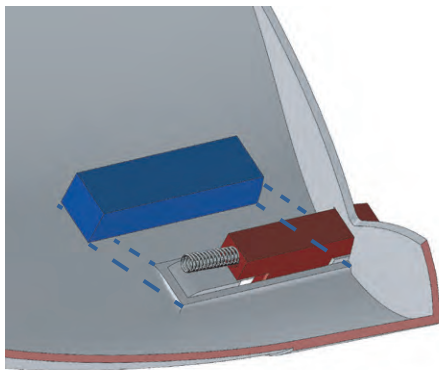

www.3DAeroventures.com

Step-by-Step Build Guide (cont'd)

Step 3. Tail Section Assembly

Tools and Materials Needed:

- Medium Bodied CA/Super Glue
- Accelerator for CA
- Sandpaper and/or Small Files
- Hobby Knife
- Dremel/Rotary tool for cutting carbon fiber tube

Hardware Needed (links to recommended hardware on pg 5):

- 3mm O.D. (or 1/8" O.D) x 10mm Long Dowel Pins (cut from scrap carbon tube/rod) (x2)
- 6mm O.D. Carbon Fiber Tubes
 - 500mm Long for Horizontal Stab
 - 220mm Long for Vertical Stab

Printed Parts Needed:

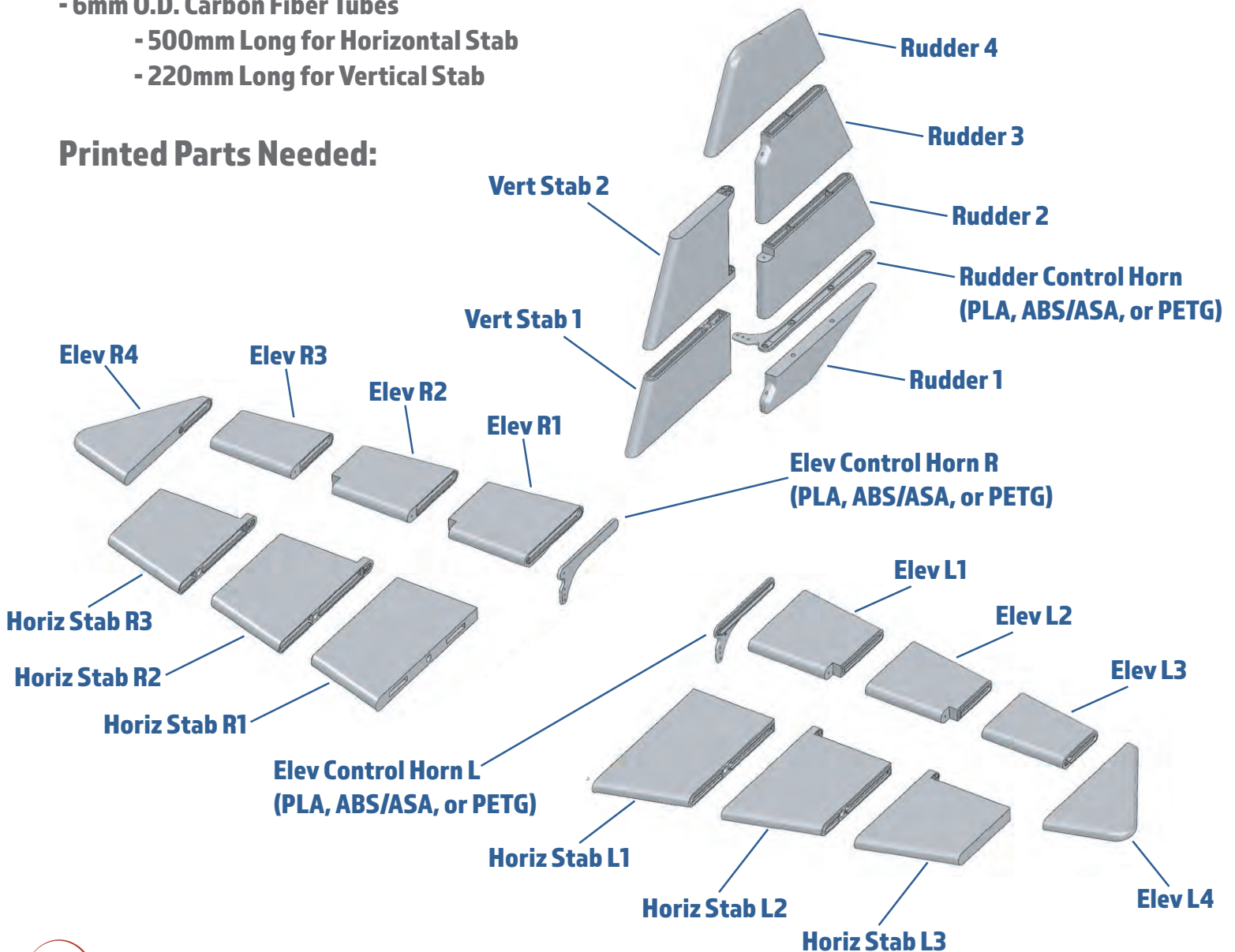

www.3DAeroventures.com

Step-by-Step Build Guide (cont'd)

Step 3.1 Cut Carbon Fiber Tubes to Length

The Horizontal Stabilizer and the Vertical Stabilizer are each reinforced with a carbon fiber tube. Cut two 6mm diameter carbon fiber tubes to these lengths using a cutting disk on a rotary tool:

- 500mm Long for Horizontal Stab
- 220mm Long for Vertical Stab

Set the tubes aside for a later step.

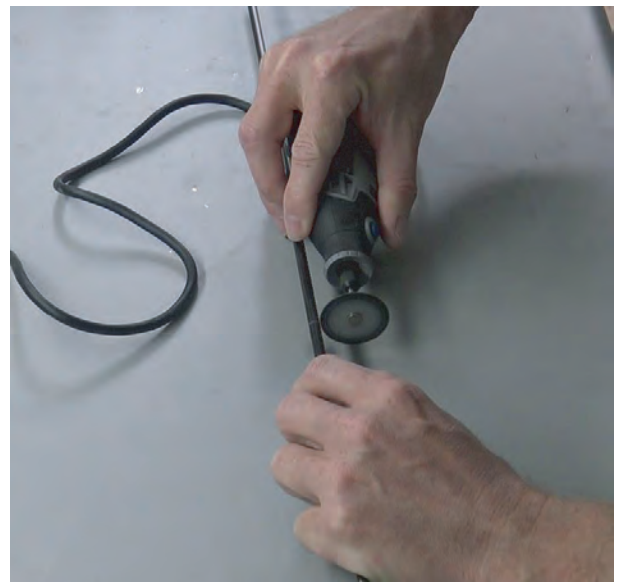

Step 3.2 Glue Vert Stab and Horiz Stab Parts Together

3.2.1 Prior to gluing the Stab parts together, make sure your carbon fiber hinge rod fits in the hinge hole on each part. If needed, clear out the hinge holes with a 1.2 to 1.7mm drill bit, depending on what size hinge rod you are using.



www.3DAeroventures.com

Step-by-Step Build Guide (cont'd)

3.2.2 Glue parts Vert Stab 1 and Vert Stab 2 together. The built-in alignment aids will keep the parts aligned, and you can use the 220mm long carbon fiber rod to further aid in alignment.

NOTE: Because of the stringing of LW-PLA you may need to clean up the alignment tabs and alignment holes with a hobby knife.



3.2.3 Using the 6mm O.D. x 220mm long carbon fiber tube, test fit the Vert Stab assembly to the fuselage to ensure it fully seats and your carbon fiber tube is cut to the proper length. If all looks good, glue the Vert Stab assembly to the fuselage.

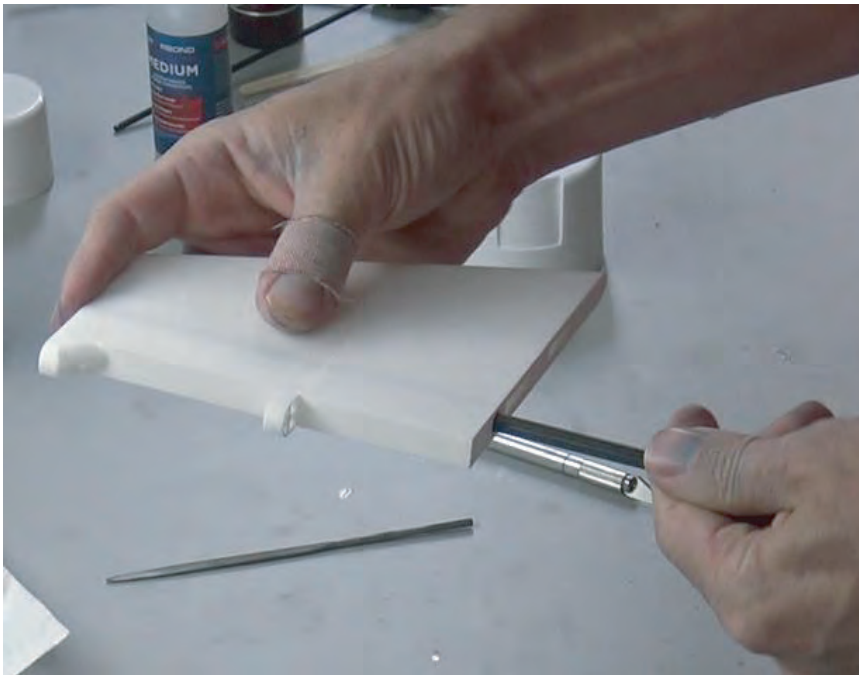

www.3DAeroventures.com

Step-by-Step Build Guide (cont'd)

3.2.4 Glue parts Horiz Stab R1, Horiz Stab R2 and Horiz Stab R3 together. The built-in alignment aid will keep the parts aligned, and you can use the 500mm long carbon fiber rod to further aid in alignment.

NOTE: To avoid confusion between the Right side and Left side Horiz Stab parts, notice each individual part is labeled with it's name. Any part that is not labeled is either easily identifiable or is a fully symmetrical part.

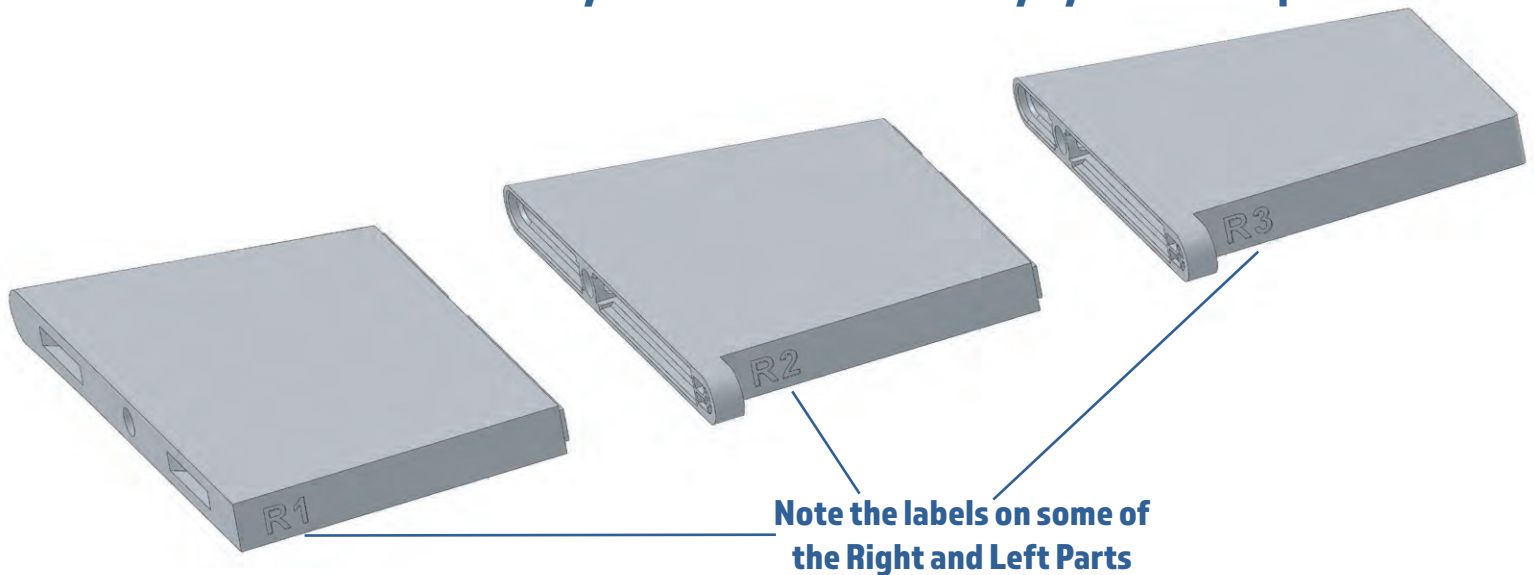

3.2.5 Repeat Step 3.2.4 for the Left Horiz Stab Parts.



www.3DAeroventures.com

Step-by-Step Build Guide (cont'd)

3.2.6 Using the 6mm O.D. x 500mm long carbon fiber tube, test fit the Horiz Stab assemblies to the fuselage to ensure they fully seat and the carbon fiber tube is cut to the proper length. If all looks good, glue the Horiz Stab assemblies to the fuselage.



www.3DAeroventures.com

Step-by-Step Build Guide (cont'd)

Step 3.3 Glue Rudder and Elevator Parts Together

3.3.1 Prior to gluing the control surface parts together, use the 1mm - 1.5mm O.D. carbon fiber rod or steel rod to make sure it slides freely in the hinge holes.

ATTENTION: The Rudder, Elevators and Ailerons are designed with separate Control Horn parts. This was done in case you choose to print the control surfaces in LW-PLA or LW-ASA. The Control Horn parts should be printed in a more rigid plastic like standard PLA, ABS, PETG, or PC for added strength.

3.3.2 Use qty. 2, 3mm diameter x 10mm long dowel pins cut from scrap wood dowels or carbon fiber rods to align parts Rudder 1 and Rudder Control Horn and glue together.

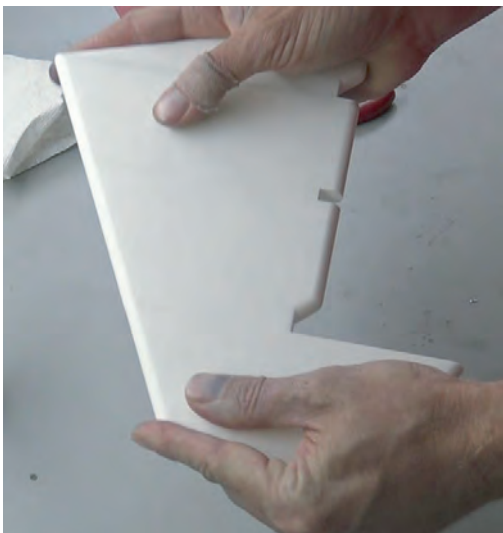

3.3.3 Continue to glue Rudder 2, Rudder 3, and Rudder 4 to the Rudder assembly using the built-in alignment aids to keep the parts aligned. The parts can also be laid on a flat surface while gluing to ensure a perfectly flat assembly. Set the Rudder aside for the Final Assembly steps later.



www.3DAeroventures.com

Step-by-Step Build Guide (cont'd)

3.3.4 Glue Parts Elev Control Horn R, Elev R1, Elev R2, Elev R3, and Elev R4 together using the built-in alignment aids to keep the parts aligned. The parts can also be laid on a flat surface while gluing to ensure a perfectly flat assembly.

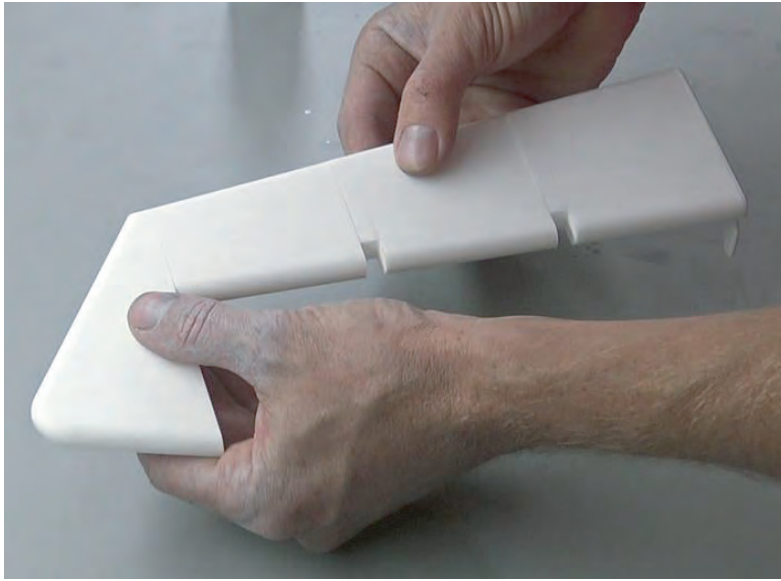

3.3.5 Repeat Step 3.3.4 for the Left Elev parts and set the elevators aside for the Final Assembly Steps later.



www.3DAeroventures.com

Step-by-Step Build Guide (cont'd)

Step 4. Wing + Aileron Assembly

Tools and Materials Needed:

- Medium Bodied CA/Super Glue
- Accelerator for CA
- Sandpaper and/or Small Files
- Hobby Knife
- Dremel/Rotary tool for cutting carbon fiber tube

Hardware Needed (links to recommended hardware on pg 5):

- M3 x 0.5mm Thread Heat-Set Threaded Inserts for Landing Gear Mounts (x8)
- 10mm O.D. Carbon Fiber Tubes for Wing Roots - 600mm (24") Long (x2)
- 6mm O.D. Carbon Fiber Tubes for Wing Tips
- 600mm (24") Long (x2)

Printed Parts Needed:

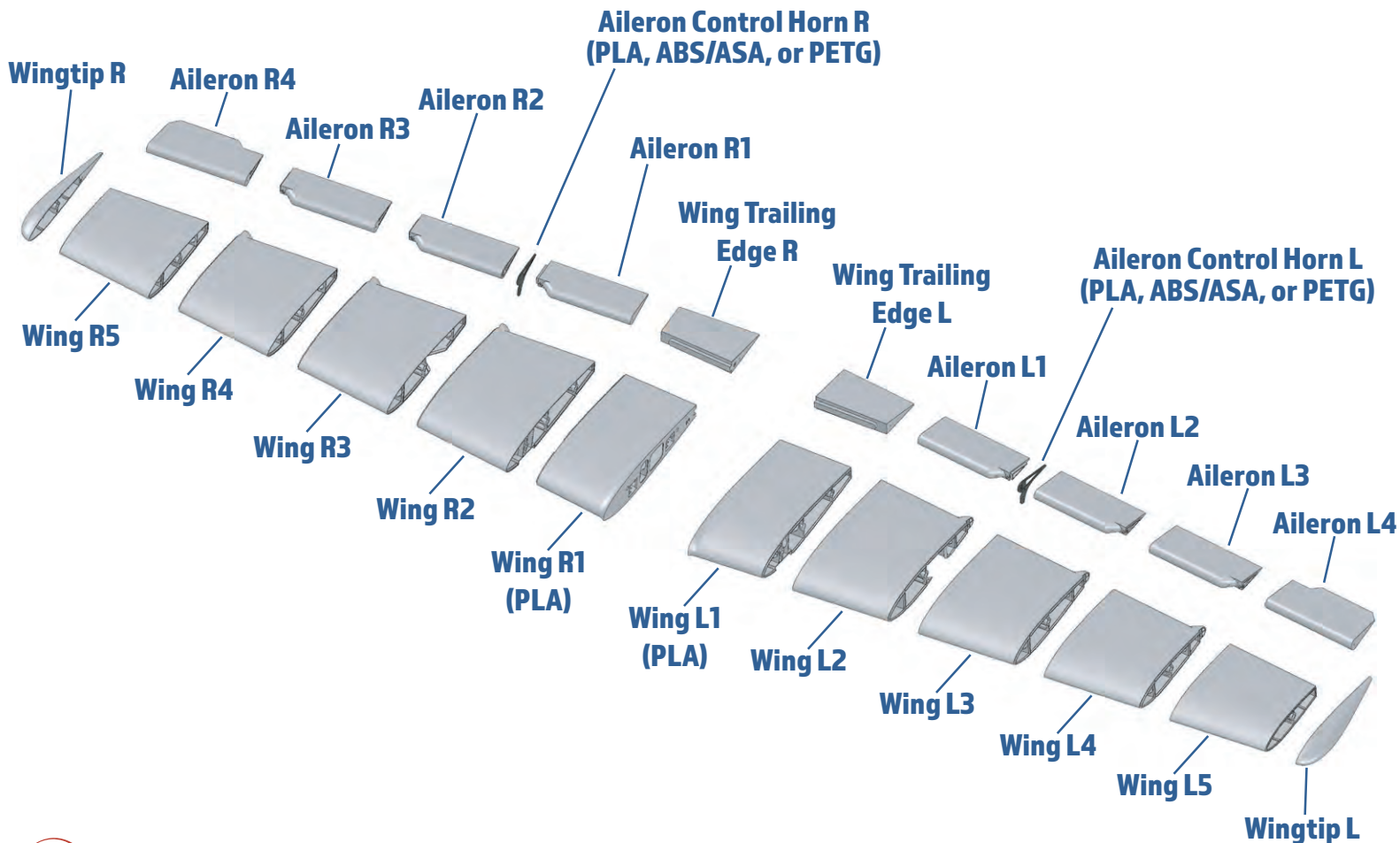

www.3DAeroventures.com

Step-by-Step Build Guide (cont'd)

Step 4.1 Cut Carbon Fiber Tubes to Length

The wing halves are reinforced with carbon fiber tubes running through the full length of the wing. Cut two 10mm diameter and two 6mm diameter carbon fiber tubes to 600mm long using a cutting disk on a rotary tool. In the USA, you can also find vendors who sell these tubes in 24" lengths, which would eliminate this step. Set the tubes aside for a later step.

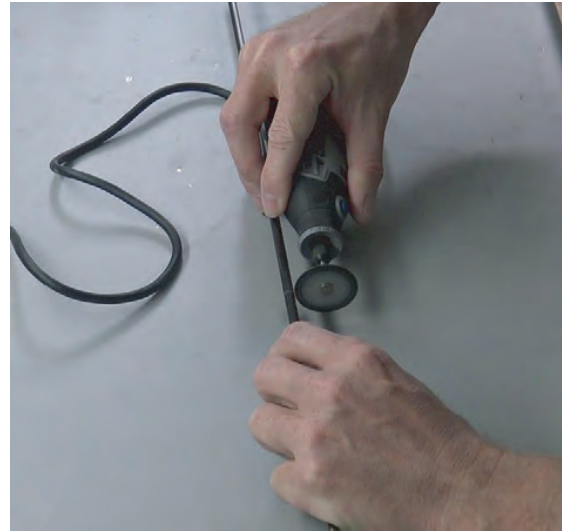

Step 4.2 Cut or Sand Away Any Stringing

When printing with LW-PLA you will likely have some residual stringing. Inspect all of the printed parts for stringing and use sand paper, a small file or a hobby knife to eliminate the stringing, especially in areas where parts will mate. You will find most of the stringing comes off quite easily.



www.3DAeroventures.com

Step-by-Step Build Guide (cont'd)

Step 4.3 Glue the Wing Parts Together

4.3.1 Prior to gluing the wing parts together, make sure your carbon fiber hinge rod fits in the hinge hole on each part. If needed, clear out the hinge holes with a 1.2 to 1.7mm drill bit, depending on what size hinge rod you are using.

4.3.2 Glue parts Wingtip R, Wing R5, Wing R4, Wing R3, and Wing R2 together. The built-in alignment aids and the carbon fiber tube will keep the parts aligned during assembly.

ATTENTION:

One of the 6mm diameter x 24" long carbon fiber tubes runs the length between Wing R2 and Wingtip R. Do not glue Wing R1 in place without this carbon fiber tube in place.

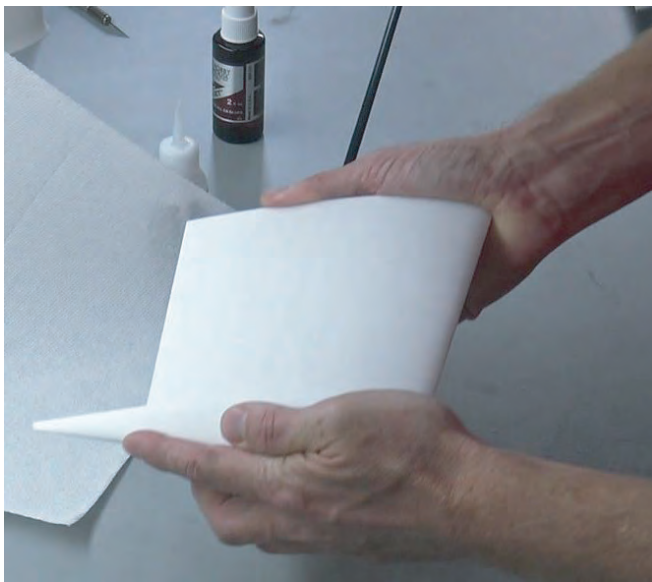
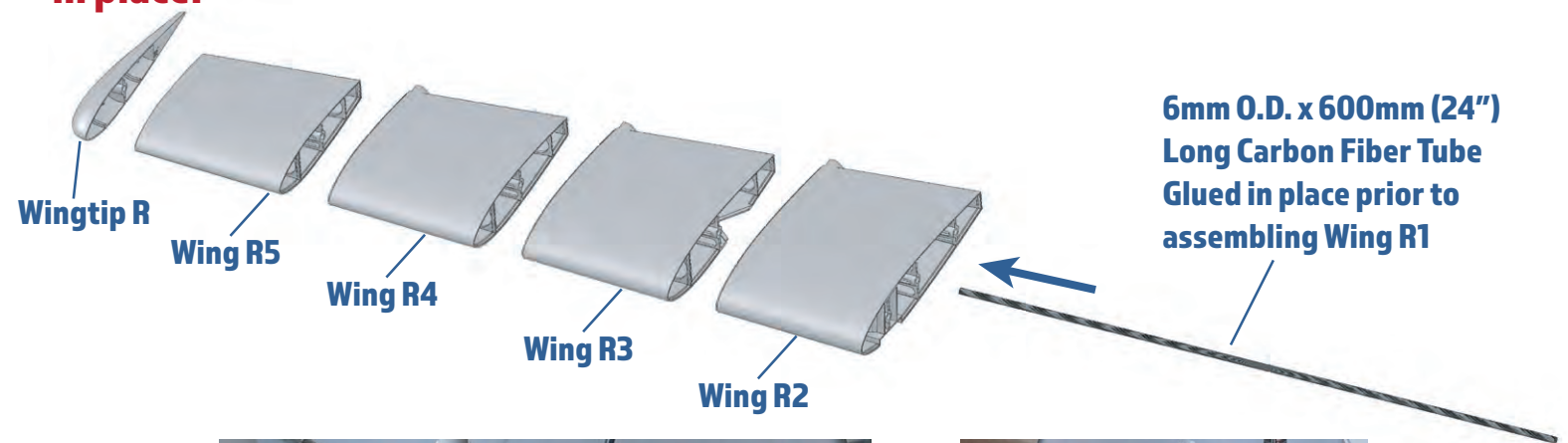

www.3DAeroventures.com

Step-by-Step Build Guide (cont'd)

- 4.3.3 Glue parts Wing R1 and Wing Trailing Edge R to the wing assembly. Wing R1 has built-in alignment aids, and you can use the two 10mm O.D. carbon fiber tubes to further aid with alignment while gluing. **Take care not to permanently glue these two carbon fiber rods in place.** Wing Trailing Edge R slides into a slot located on the back of Wing R1

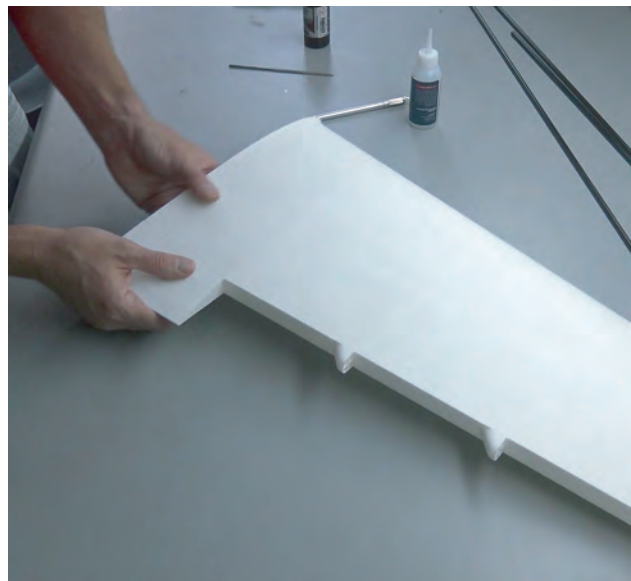
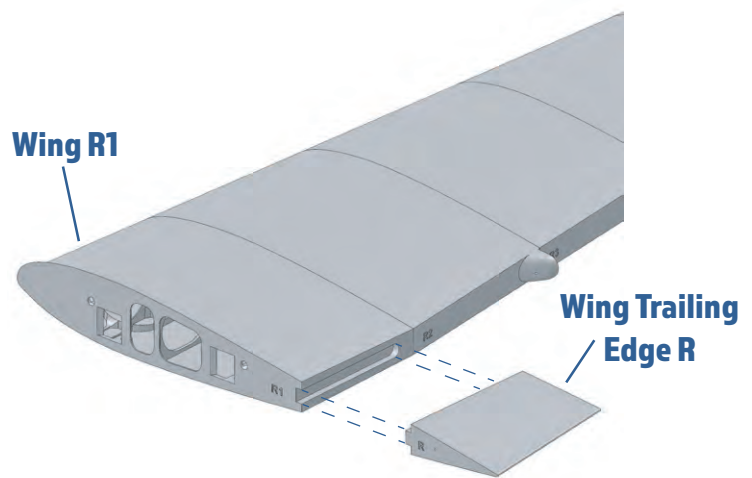

www.3DAeroventures.com

Step-by-Step Build Guide (cont'd)

4.3.4 Use a soldering iron to sink qty. 4, M3 x 0.5 Thread Heat-Set Inserts in place in the landing gear mounting holes, which are located on the bottom of Wing R1 and Wing R2



Place M3 Heat-Set Inserts Here

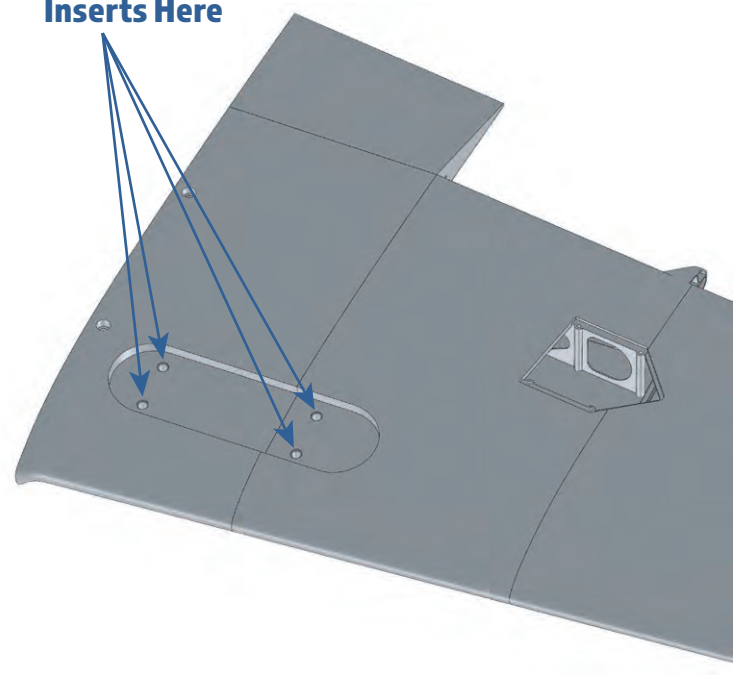

4.3.5 Repeat Steps 4.3.1 thru 4.3.4 to assemble the Left Wing



www.3DAeroventures.com

Step-by-Step Build Guide (cont'd)

Step 4.4 Glue Aileron Parts Together

4.4.1 Prior to gluing the aileron parts together, use the 1mm - 1.5mm O.D. carbon fiber rod or steel rod to make sure it slides freely in the hinge holes.

ATTENTION: The Rudder, Elevators and Ailerons are designed with separate Control Horn parts. This was done in case you choose to print the control surfaces in LW-PLA or LW-ASA. The Control Horn parts should be printed in a more rigid plastic like standard PLA, ABS, PETG, or PC for added strength.

4.4.2 Glue parts Aileron R1, Aileron Control Horn R and Aileron R2 together. The Aileron Control Horn R is glued in between Aileron R1 and Aileron R2, as shown in the image below. The built-in alignment aids will keep the parts aligned. Ensure you have the control horn in the correct orientation before gluing.

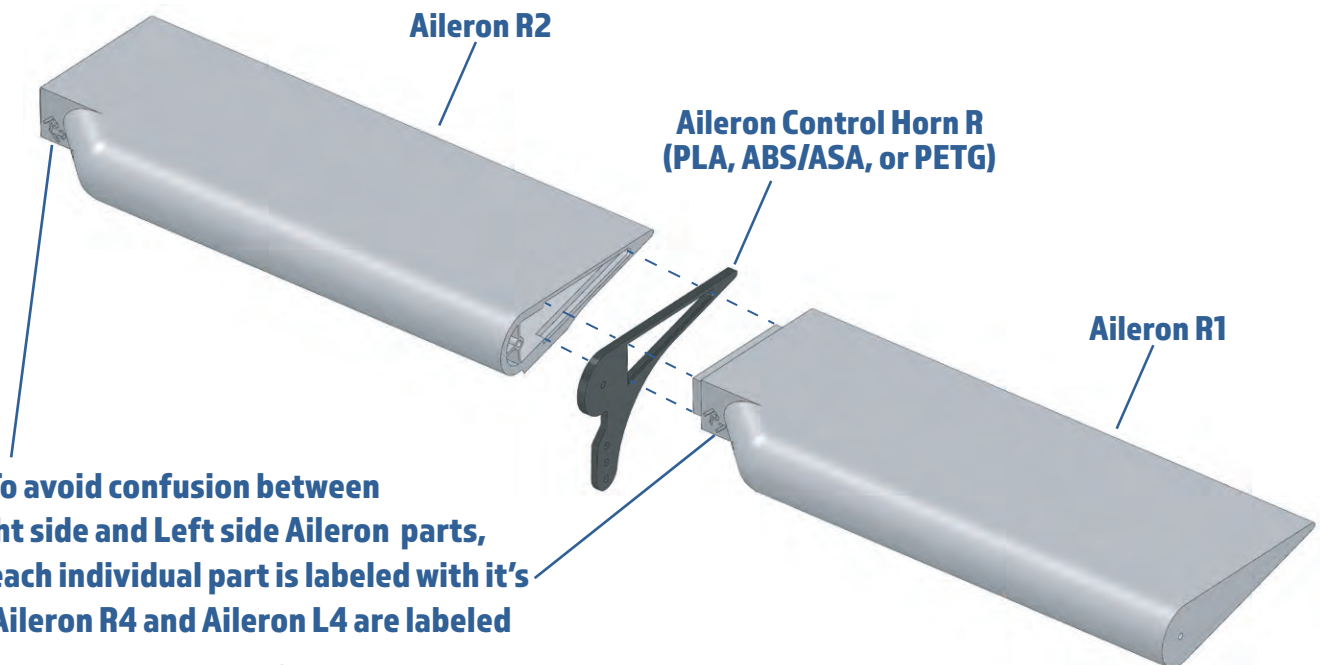

NOTE: To avoid confusion between the Right side and Left side Aileron parts, notice each individual part is labeled with it's name. Aileron R4 and Aileron L4 are labeled inside the hollow portion of the parts.



www.3DAeroventures.com

Step-by-Step Build Guide (cont'd)

4.4.3 Glue parts Aileron R3 and Aileron R4 to the Right Aileron assembly. The built-in alignment aids will keep the parts aligned. The parts can also be laid on a flat surface while gluing to ensure perfectly flat assembly.

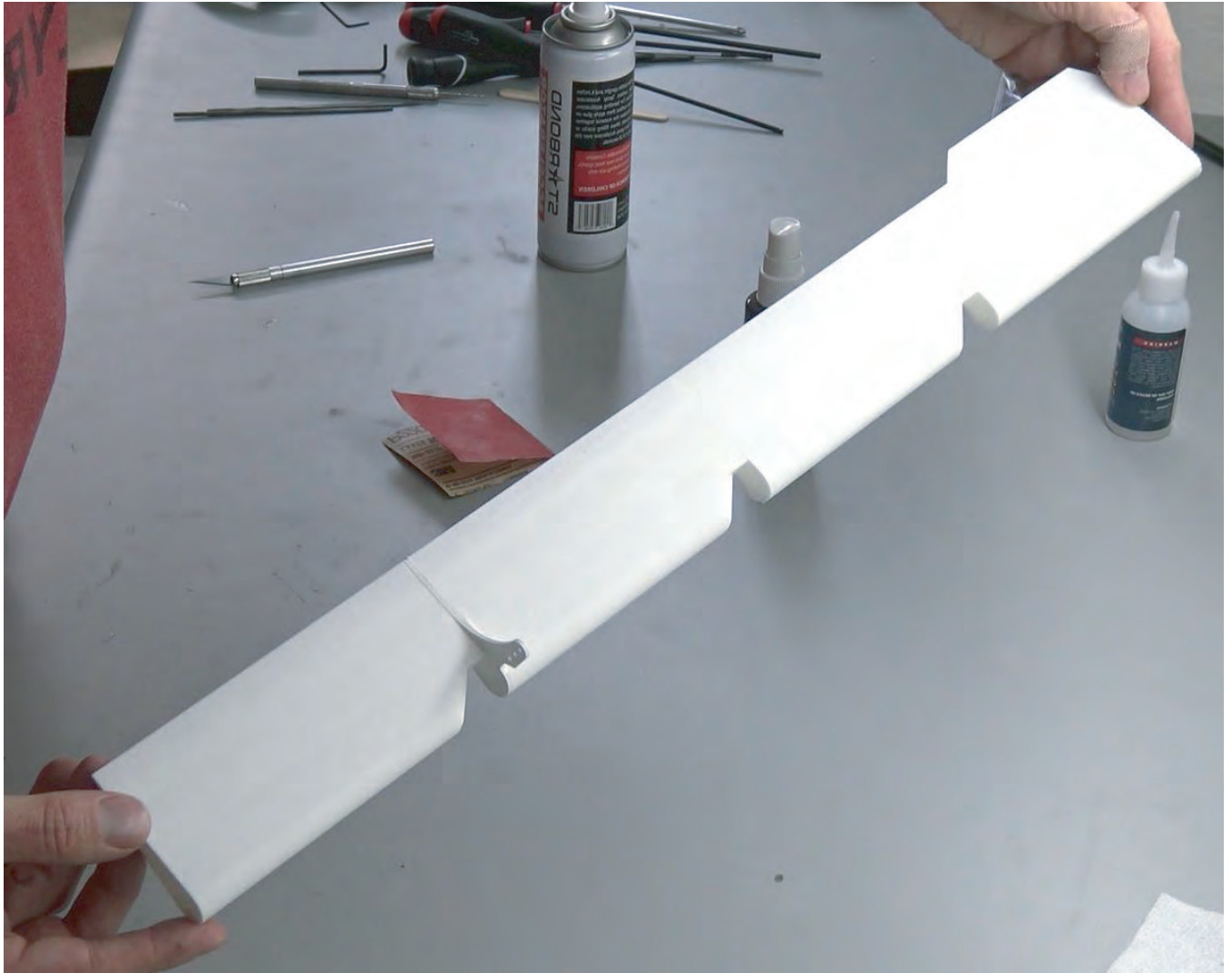

4.4.4 Repeat steps 4.4.1 thru 4.4.3 to assemble the Left Aileron.



www.3DAeroventures.com

Step-by-Step Build Guide (cont'd)

Step 5. Cowling & Landing Gear Assembly

Tools and Materials Needed:

- Medium Bodied CA/Super Glue
- Accelerator for CA
- Sandpaper and/or Small Files
- Hobby Knife
- Needle Nose Pliers
- Allen wrench for 5mm socket head screw
- Allen wrench for wheel collars

Hardware Needed (links to recommended hardware on pg 5):

- 3mm O.D. (or 1/8" O.D) x 10mm Long Dowel Pins (cut from scrap carbon tube/rod) (x4)
- M5 x 0.8mm Thread x 40mm Long Screws for Wheels (x2)
- M5 x 0.8mm Thread Lock Nuts for Wheels (x2)
- Steel washer for M5 Screw Size (x2)
- Wheel Collars to fit 5mm rod

Printed Parts Needed: (PLA, ABS/ASA, or PETG)

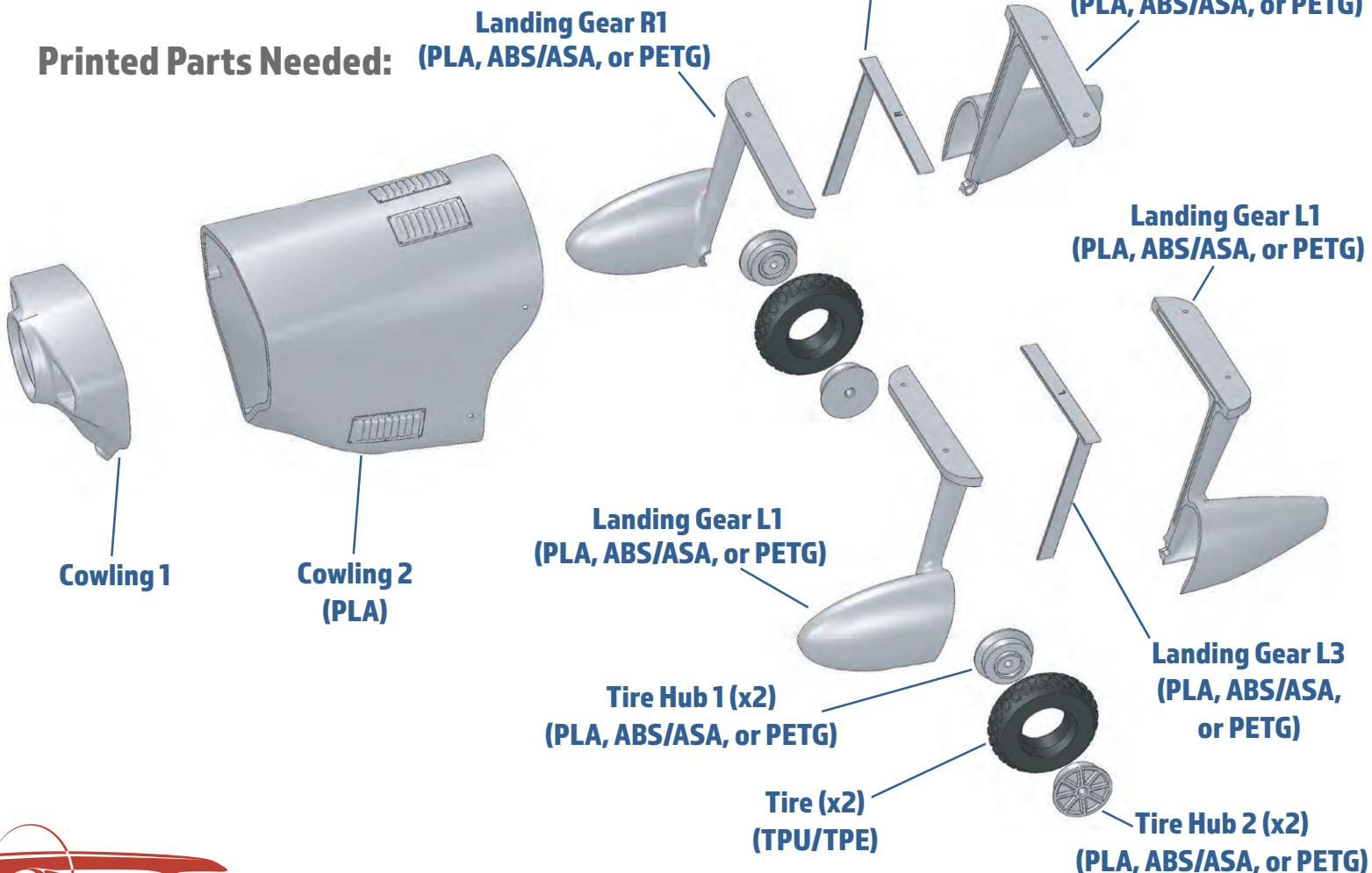

www.3DAeroventures.com

Step-by-Step Build Guide (cont'd)

Step 5.1 Glue Cowling Parts Together

5.1.1 The Cowling 1 part is designed with removable support structures. These supports should will pop off by hand and should be removed prior to assembly.

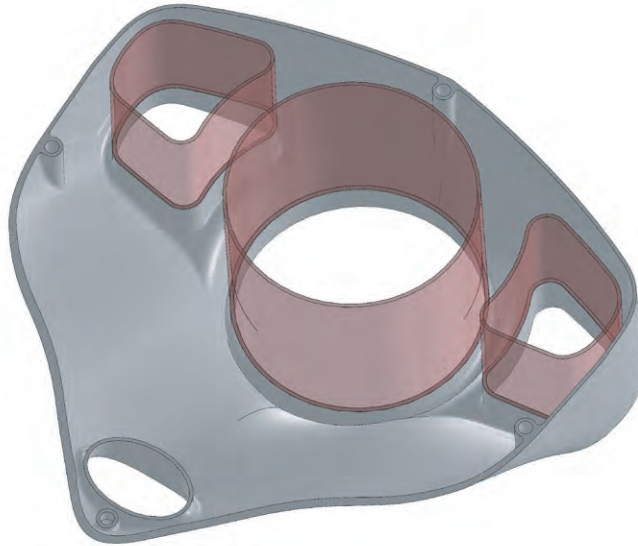

5.1.2 Use qty. 4 , 3mm diameter x 10mm long dowel pins cut from scrap wood dowels or carbon fiber rods to align Cowling 1 to Cowling 2 and glue together. You may need to clear out the dowel pin holes with a 3mm or 1/8" drill bit.

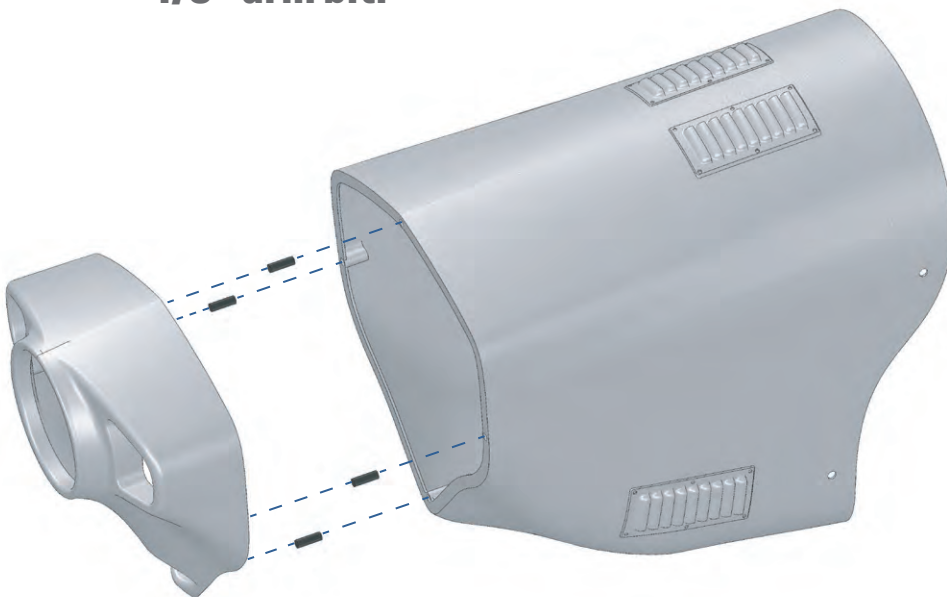

www.3DAeroventures.com

Step-by-Step Build Guide (cont'd)

Step 5.2 Assemble the Landing Gear Parts

5.2.1 Choose your preferred landing gear style from the two options. Option 1 is with wheel pants and Option 2 is without wheel pants, which may be a better option if you fly off of taller grass. Or, since the landing gear is designed to bolt on, you can print both styles and swap them out whenever you want!

5.2.2 The Landing Gear R3 part is an alignment aid designed to fit in the slots in Landing Gear R1 and Landing Gear R2. Glue Landing Gear R3 into the slot in Landing Gear R1, and then Glue Landing Gear R2 to the assembly.

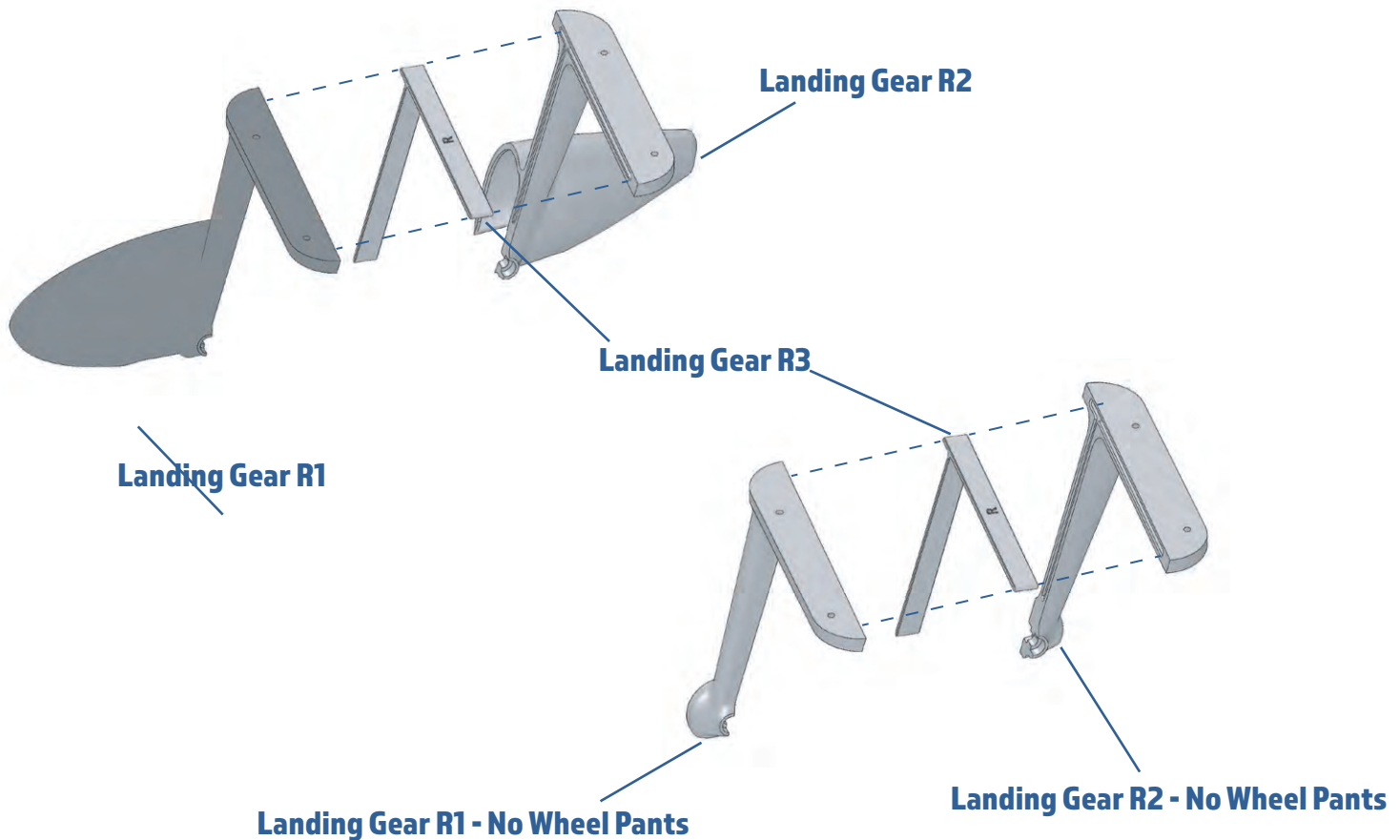

5.2.3 Repeat step 5.2.2 to assemble the Left landing gear parts.



www.3DAeroventures.com

Step-by-Step Build Guide (cont'd)

5.2.4 Apply glue to Tire Hub 1 in the areas that connect with Tire Hub 2, insert Tire Hub 1 into the Tire and then insert Tire Hub 2 and spray with Accelerator to speed up the bond. Repeat this step to assemble a second tire.

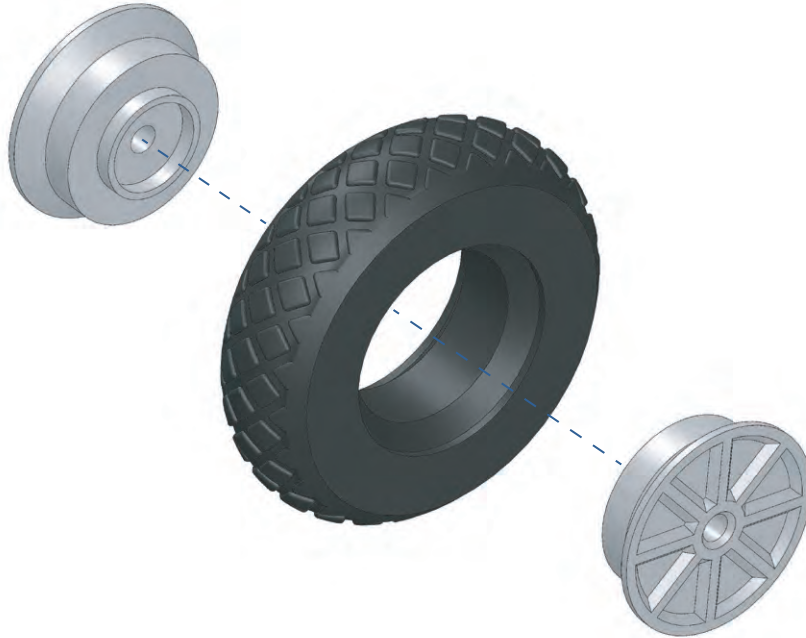

5.2.4 If you are going to paint your aircraft it is recommended that you paint the landing gear struts/wheel pants prior to bolting on the wheels. Bolt the wheels in place with the M5 x 40mm long pan head screws, using a washer and M5 locknut on the inside of the wheel pant to secure the bolt in place. Secure the 5mm wheel collar on the other side of the wheel

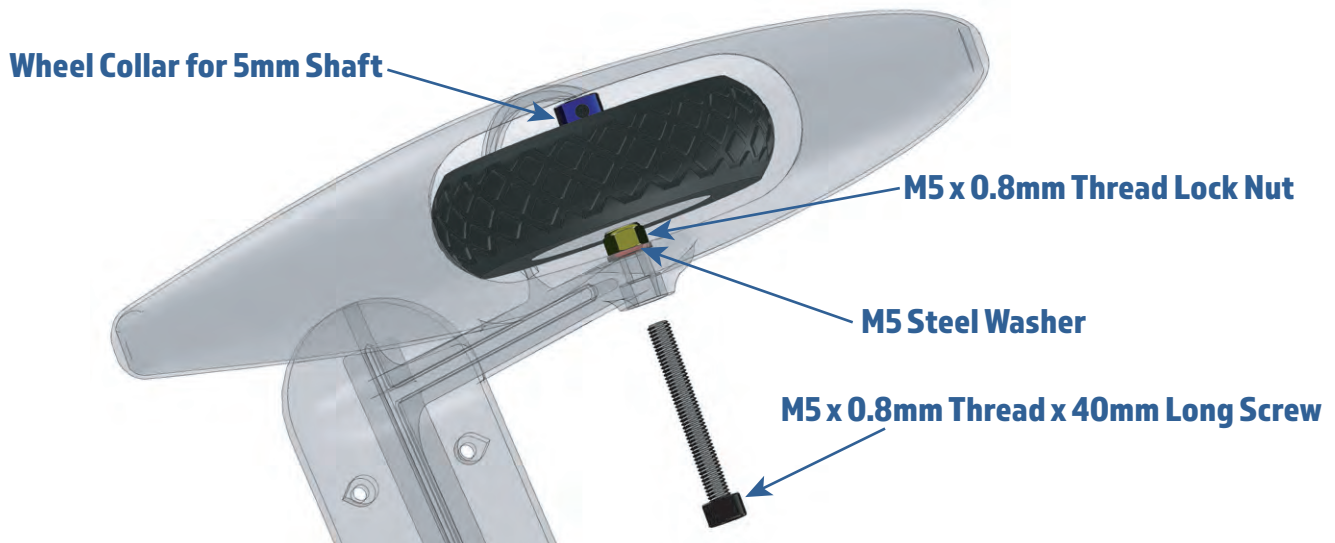

www.3DAeroventures.com



Step-by-Step Build Guide (cont'd)

Step 6. Painting/Finishing (Optional)

Tools and Materials Needed:

- 150 Grit, 220 Grit, 400 Grit Sandpaper
- 1500 or 2000 Grit Sandpaper
- Isopropyl Alcohol/Rubbing Alcohol
- Acrylic Spray Paint Colors of your choice. Or use an airbrush system.
- Pinstripe tape, masking tape, and plastic wrap for masking off parts
- Flexible steel wire for hanging parts while painting and drying
- Paper towels or lint free cloth

Step 6.1 Sanding

6.1.1 Sand all of the parts with 150 grit sandpaper to remove the larger imperfections and break down the layer lines. Then sand the parts with 220 grit, followed by 400 grit sandpaper to further smooth the parts.

6.1.2 Lightly wipe down all parts with isopropyl alcohol to remove any residual dust from sanding.



www.3DAeroventures.com

Step-by-Step Build Guide (cont'd)

Step 6.2 First Coat

- 6.2.1** Spray the parts with a first coat of acrylic spray paint. This helps fill some small gaps, it helps tape and decals stick to the parts better, and it slightly stiffens the LW-PLA parts.
- 6.2.2** Let the parts dry per the paint manufacturer's instructions and then lightly sand with 1500 or 2000 grit sand paper to smooth out the paint.

Step 6.3 Masking/Painting/Final Clearcoat

Use different types of tape to layout the paint design and block the paint from getting in the undesired areas.

- 6.3.1** Mask the fine detail parts, such as the window areas, and any curved areas with a flexible pinstripe tape. We used 3mm or 1/8" wide pinstripe tape.
- 6.3.2** Mask off larger areas with standard masking/painter's tape
- 6.3.3** Mask off the largest areas with kitchen plastic wrap or newspaper

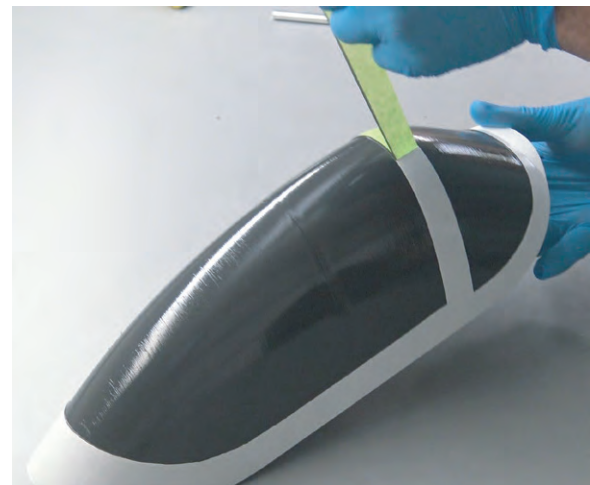

www.3DAeroventures.com

Step-by-Step Build Guide (cont'd)

6.3.4 Spray paint with your color choices in light coats. Start the spray off of the part and wave the spray across your part with the nozzle 8 - 10 inches away from the part. Spray multiple light coats until you achieve full coverage. Avoid overspraying to minimize the risk of getting runny paint.

6.3.5 After applying your color spray you can apply decals or pinstriping. In my case, I used scale decals purchased in the United States from www.callie-graphics.com

After applying decals, give the model a final light clear coat with a clear spray paint.



www.3DAeroventures.com

Step-by-Step Build Guide (cont'd)

Step 7. Final Assembly

Tools and Materials Needed:

- Medium Bodied CA/Super Glue
- Accelerator for CA
- Allen wrench for 3mm and 4mm socket head screw
- Allen wrench for wheel collars

Hardware Needed (links to recommended hardware on pg 5):

- M3 x 0.5mm Thread x 12mm Long Screws for Landing Gear (x8)
- M4 x 0.7mm Thread x 16mm Long Screws for Motor Mount (x4)
- 1mm - 1.5mm O.D. Carbon fiber rod or Steel Wire
 - 650mm Long for Aileron Hinges (x2)
 - 550mm Long for Elevator Hinge
 - 220mm Long for Rudder Hinge
- Wheel Collar to fit 2mm rod (tailwheel)

Printed Parts Needed:

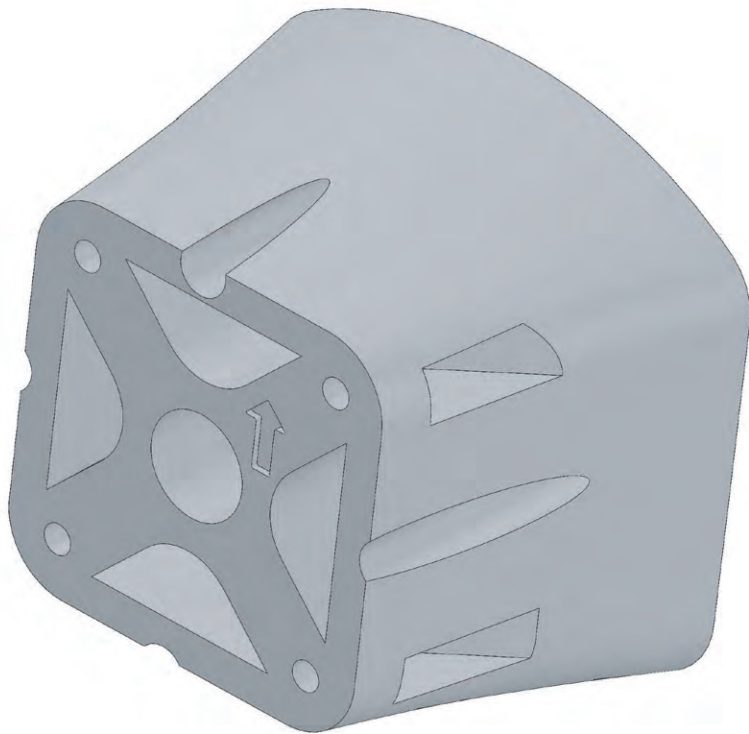

Motor Mount - Leopard 5065
Motor Mount - Leopard 5055
or
Motor Mount - Turnigy SK3 5055



www.3DAeroventures.com

Step-by-Step Build Guide (cont'd)

Step 7.1 Install Landing Gear

7.1.1 Mount the landing gear assemblies to the bottom of the right and left wings using the M3 x 0.5mm Thread x 12mm Long Screws

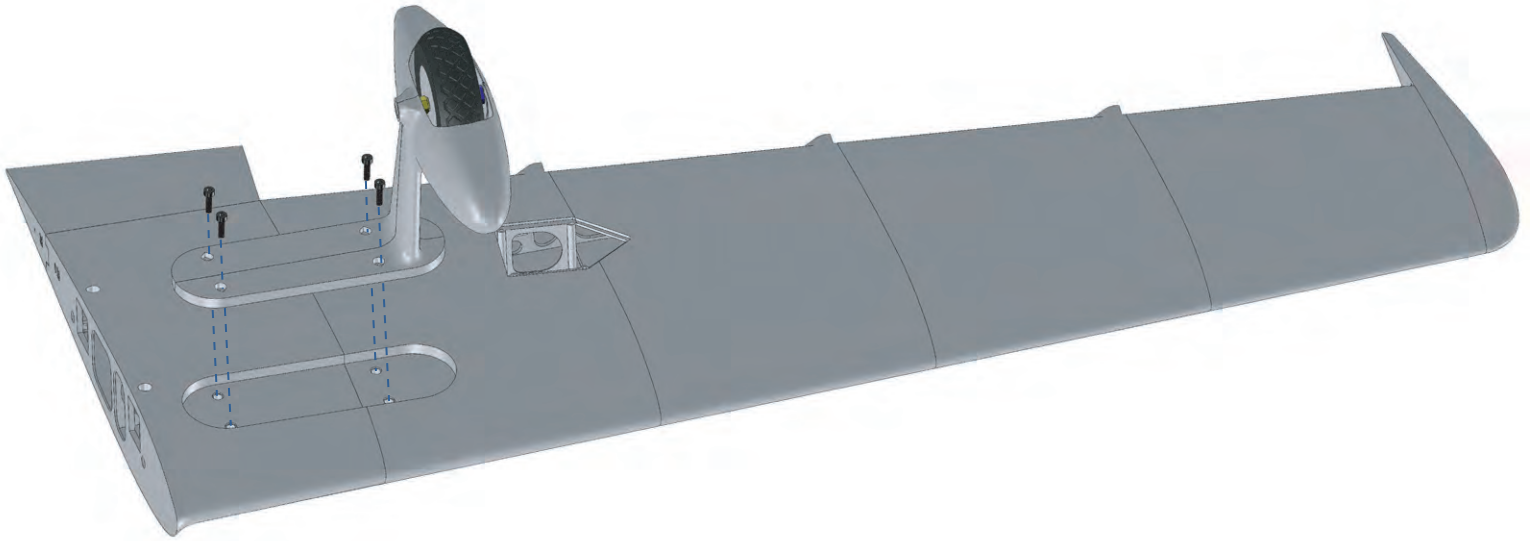

7.1.2 Apply glue to Tailwheel Hub 1 in the areas that connect with Tailwheel Hub 2, insert Tailwheel Hub 1 into the Tailwheel Tire and then insert Tailwheel Hub 2 and spray with accelerator to speed up the bond. Place the tailwheel on the tailwheel wire and secure with the 2mm wheel collar.

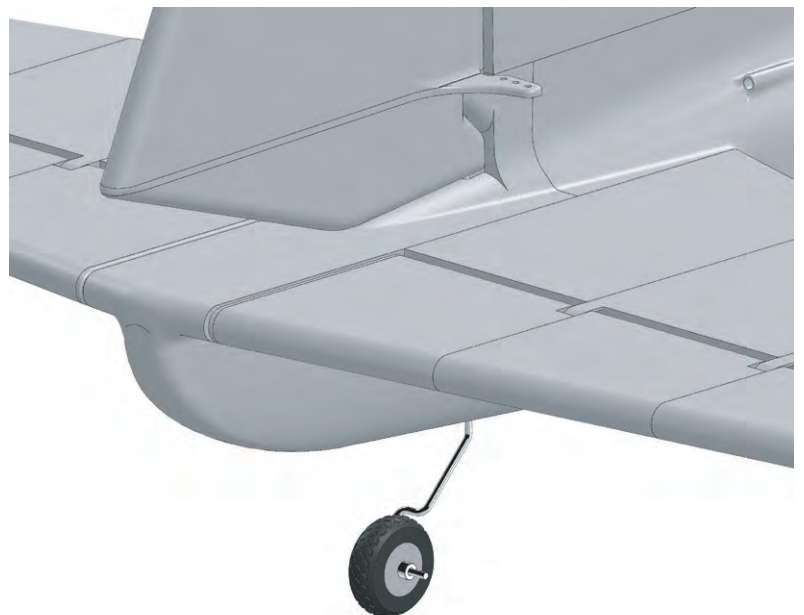

www.3DAeroventures.com

Step-by-Step Build Guide (cont'd)

Step 7.2 Install Motor Mount

7.2.1 Choose one of the included motor mount options that will work for one of the recommended motors. If you are using a different motor than what is recommended, make sure the hole spacing dimension on the X-mount pattern matches the dimension shown in the image below.

7.2.1 Screw the Motor Mount onto the fuselage firewall using qty. 4, M4 x 0.7mm Thread x 16mm Long Screws.

ATTENTION: The motor mount is designed with a few degrees of right thrust and down thrust angles and must be mounted in the proper orientation. Make sure the arrow that is on the face of the motor mount is facing up.

Ensure the arrow on the face of the motor mount is facing up when mounted.

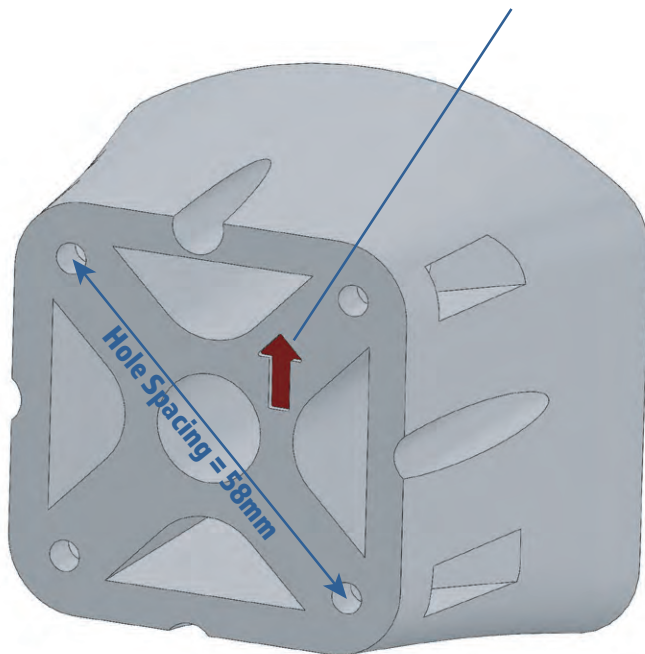

www.3DAeroventures.com

Step-by-Step Build Guide (cont'd)

Step 7.3 Install Control Surfaces and Hinges

7.3.1 Attach the Right Aileron to the Right Wing by routing the 1mm - 1.5mm O.D. x 650mm long carbon fiber rod through the hinge holes in the wing and aileron. The carbon fiber rod can be inserted through either the wingtip or the wing root. Alternatively, If you have trouble finding a 650mm long carbon fiber rod you can use qty. 2, 325mm long rods. Insert one rod through the wingtip and one through in the wing root until they meet in the middle. Place a drop of CA glue in the rod entry holes to prevent the rod from sliding out.



7.3.2 Repeat step 7.3.1 to attach the Left Aileron to the Left Wing



www.3DAeroventures.com

Step-by-Step Build Guide (cont'd)

7.3.3 Slide the rudder onto the exposed tailwheel wire until it is fully seated. Attach the Rudder to the Vert Stab with the 1mm - 1.5mm O.D. x 220mm long carbon fiber rod. Place a drop of CA glue in the rod entry hole to prevent the rod from sliding out.



7.3.4 Hold both Elevators in place on the Horizontal Stabs and permanently attach them both with the 1mm - 1.5mm O.D. x 550mm long carbon fiber rod. Alternatively, If you have trouble finding a 550mm long carbon fiber rod you can use qty. 2, 275mm long rods. Insert one rod through Elev R4 and one through Elev L4 until they meet in the middle. Place a drop of CA glue in the rod entry holes to prevent the rod from sliding out.



www.3DAeroventures.com

Step-by-Step Build Guide (cont'd)

Step 8. Final Radio and Motor Installation

Tools and Materials Needed:

- Screwdriver for servo mounting screws and servo covers
- Allen wrench for M3 screws
- Needle nose pliers
- Velcro strips with adhesive backing

Hardware/Electronics Needed (links to recommended hardware on pg 5):

- 2mm (or 2-56) diam. steel wire with threaded ends for servo control rods
 - 30" long for elevator (x2) and rudder
 - 12" long for ailerons (x2)
- M2 or #2 Thread Forming or Tapping Screws for mounting servo covers (x8)
- M4 x 0.7mm Thread x 16mm Long Screws for Motor Mount (x4)
- M4 x 0.7mm Thread Lock Nut for Motor Mount (x4)
- M3 x 0.5mm Thread x 25mm Long Screws for Spinner (x2)
- M3 x 0.5mm Thread Lock Nuts for Spinner (x2)
- M3 x 0.5mm Thread x 12mm Long Screws for Cowling (x4)
- Pushrod Connectors like Nylon or Steel Kwik-Links (x5)
- Motor: Leopard 5065-7T
- ESC: 80A Esc
- Rec. Prop: 15 x 8 to 16 x 10
- Battery: 6S 5000mAh LiPo or 5S 5000 mAh
- Radio: Radio + 4 - 6 Channel Receiver
- Servos:
 - EMAX ES3004 or EMAX ES3054 (x2) for Ailerons
 - EMAX ES3004 or EMAX ES3054 (x2) for Elevators
 - EMAX ES-3005 or Flite Test ES3005 or EMAX ES3001 (x1) for Rudder
- 4" Servo Extensions for aileron servos (x2) and 6" Servo Extensions for Receiver (x2)

Printed Parts Needed:



www.3DAeroventures.com



Step-by-Step Build Guide (cont'd)

Step 8.1 Install Servos

8.1.1 Using the mounting screws that came with your servos, mount the rudder and elevator servos in the fuselage servo tray.

Note: It is recommended to test and center the servos prior to installation.



8.1.2 Print out the drawing of the elevator and rudder pushrods on the following page to aid in bending the threaded end of the 30" long 2mm (or 2-56) diameter wire to the proper shapes. You will need two pushrods for the elevator halves, and one pushrod for the rudder. Slide the pushrods into the guide tubes built into the fuselage and trim the pushrods to length to line up with the elevator and rudder servos. Make sure to leave some excess length for running through a pushrod connector or creating a z-bend.

8.1.3 Install the servo control arms and attach the pushrods to the servos with a z-bend or with a pushrod connector.

8.1.4 Screw the nylon or steel kwik-links onto the threaded ends of the rudder and elevator pushrods and attach them to the control surfaces.

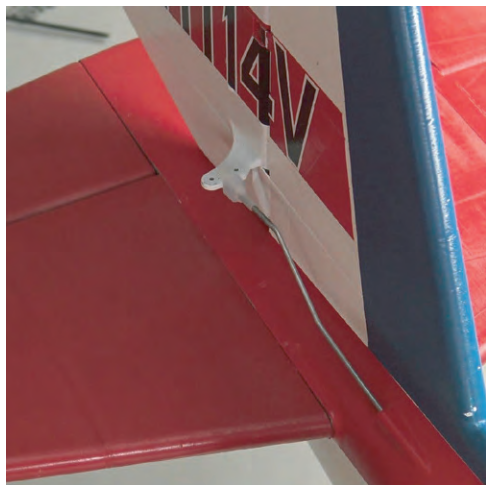

www.3DAeroventures.com

Step-by-Step Build Guide (cont'd)

**Elevator Pushrod
2mm (or 2-56) Diameter Wire
with Threaded End**

Scale 1:1



Qty. 2 required

**Rudder Pushrod
2mm (or 2-56) Diameter Wire
with Threaded End**

Scale 1:1

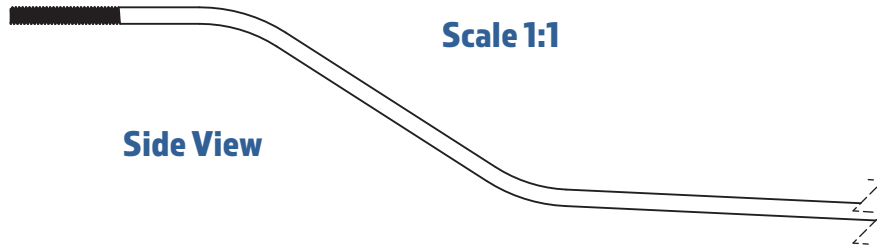

www.3DAeroventures.com

Step-by-Step Build Guide (cont'd)

8.1.5 Attach the 4" servo extensions to your aileron servos and, using the mounting screws that came with your servos, mount the aileron servos to the Wing Servo Covers.

Note: It is recommended to test and center the servos prior to installation.

8.1.6 Route the aileron servo wires through the servo cover openings in the bottom of the wings and out the root of the wings. Use the M2 or #2 thread forming screws to mount the Wing Servo Covers to the wings.

8.1.7 Cut the 12" aileron pushrods to the proper length and screw a nylon or steel kwik-link into the threaded end. Attach the pushrods to the servo control arms with a z-bend or with a pushrod connector, then attach the kwik-links to the ailerons.

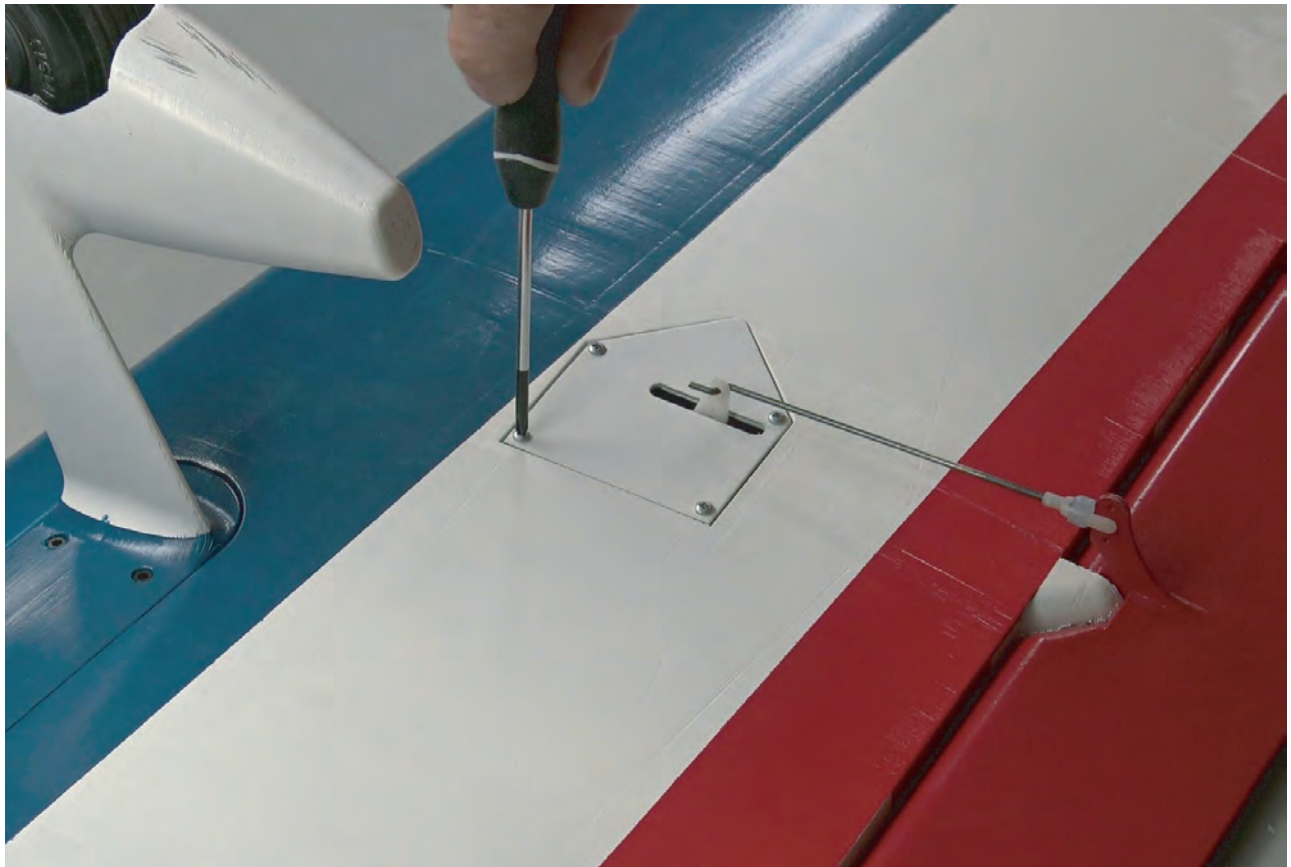

www.3DAeroventures.com

Step-by-Step Build Guide (cont'd)

Step 8.2 Install Motor, ESC, and Receiver

8.2.1 Screw the motor to the Motor Mount using the M4 x 16mm Long Screws and M4 locknuts. The locknuts are inserted into the sides of the motor mount as shown in the rendering below.

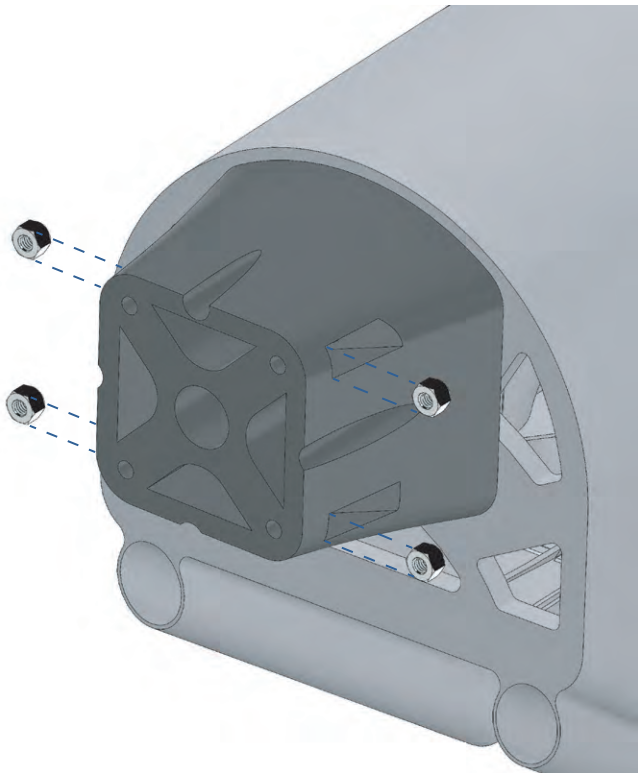

8.2.2 Install the ESC and receiver. Use velcro with adhesive backing to attach the ESC and receiver to the fuselage tray, out of the way of where you will place the battery. Install the 6" servo extensions to the two ports on the receiver that you will use to mix the aileron servos together. If you do not have mixing capabilities on your receiver you can use a Y-harness servo extension. You will also need a Y-harness and a [servo reversing lead](#) for one of the elevator servos if you can not mix the two elevator servos together.



www.3DAeroventures.com

Step-by-Step Build Guide (cont'd)

8.2.3 Bolt on the cowling using the M3 x 12mm long screws, install your propeller and spinner (optional), attach the canopy, and bolt on the wings in preparation for balancing the aircraft. Be sure to use the two 6mm diameter carbon fiber wing tubes when bolting on your wings. Be sure to plug your aileron servos in as well, in preparation for setting the control surface throws and exponential.

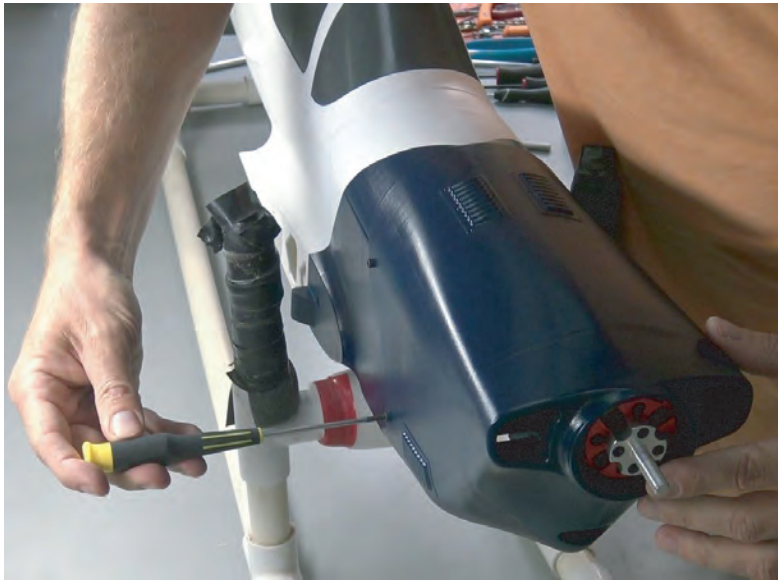

www.3DAeroventures.com

Step-by-Step Build Guide (cont'd)

8.2.4 Finally, install a 6S or 5S battery size in a location that will properly balance the aircraft. A 6S is recommended for the heavier PLA, ABS/ASA, or PETG version, while a 5S will sufficiently power the LW-PLA Hybrid version. Balance the aircraft along the recommended Center of Gravity position. The Center of Gravity position for the aircraft is located between 75mm - 85mm behind the leading edge of the wing, as shown in the image below. Remember to err on the side of slightly nose heavy for your first flight and adjust from there.

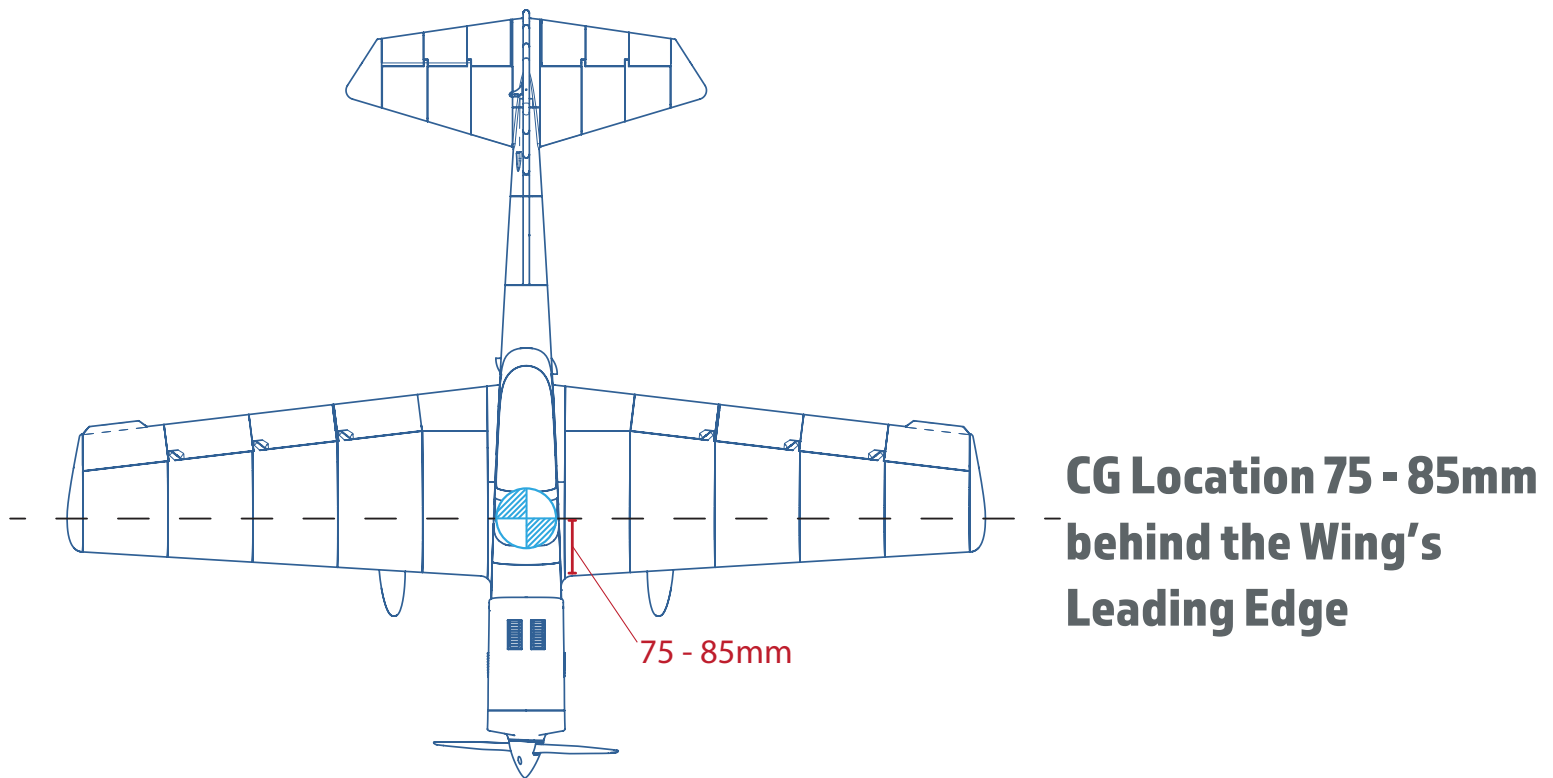

8.2.5 Once you are happy with where the battery is located for balancing, attach a long strip of velcro with adhesive backing to the fuselage tray and the battery, and use two velcro straps to hold the battery in place during flight.



www.3DAeroventures.com

Step-by-Step Build Guide (cont'd)

8.2.6 Connect the battery, bind your radio, and follow the instructions included with your radio for setting your drive rates and exponential.

Recommended Rates and Exponential:

Ailerons

Low Rate



Exponential: 15%

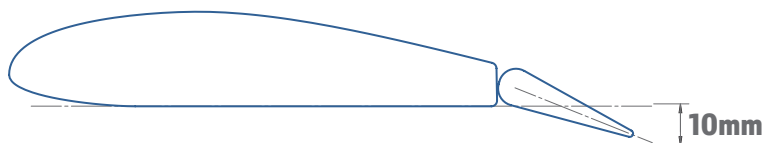

High Rate



Exponential: 30%

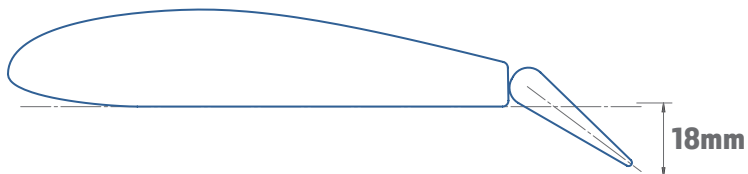

Elevator

Low Rate



Exponential: 15%

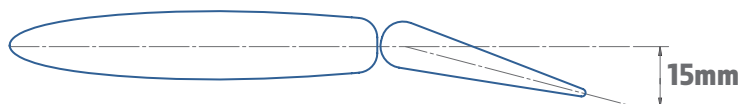

High Rate

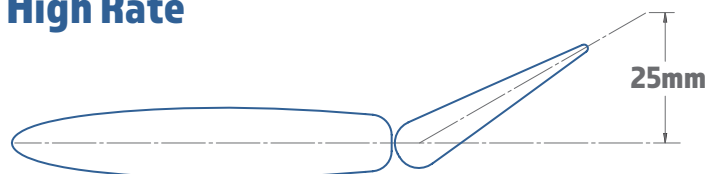

Exponential: 30%

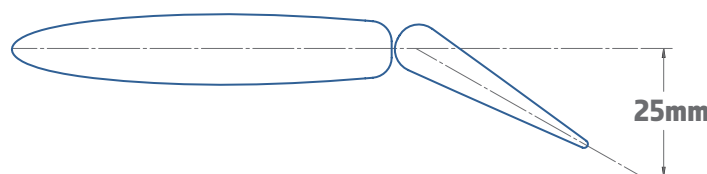

www.3DAeroventures.com

Step-by-Step Build Guide (cont'd)

Recommended Rates and Exponential:

Rudder (Measured at the Front of the Rudder)

Low Rate

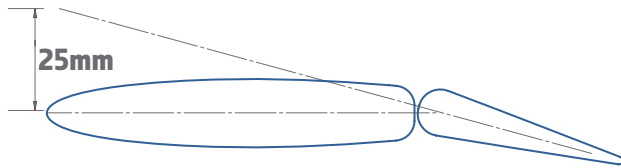

Exponential: 15%

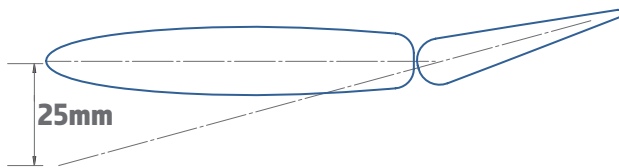

High Rate

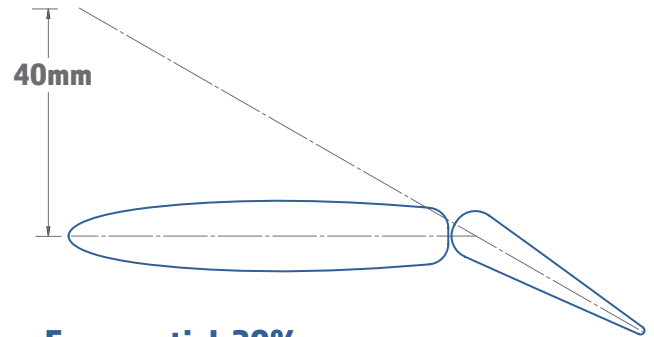

Exponential: 30%

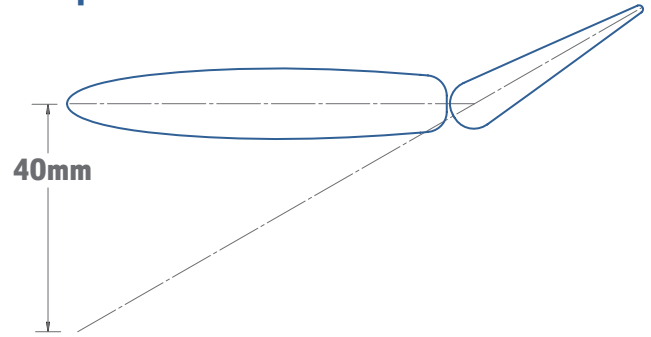

www.3DAeroventures.com

Tips For Your First Flight

Weather:

Due to the larger size of the Super Chipmunk, it can handle mild to moderate winds. But It is recommended to fly on calm days, with winds between 0 - 10 mph. With any R/C aircraft, always ensure you are taking off and landing into the wind. Keep in mind that LW-PLA is particularly susceptible to warping in direct sunlight on hot days. Keep your aircraft in the shade when you're not flying.



Pre-Flight Checks:

1. Double check all screws to ensure they are tight, including servos, control horns, motor mount, and props.
2. Ensure servo extensions and all electronics are fully plugged in.
3. Radio and onboard LiPo batteries are fully charged
4. It is recommended to test your radio from long range (30 or more paces away from the aircraft) to ensure your radio signal is strong and you don't experience servo flutter.
5. Double check all controls are moving the proper direction!



www.3DAeroventures.com

About 3DAeroventures

3DAeroventures is a YouTube channel and eCommerce store where content creator and Pilot in Command, Eric Haddad, uses engineering technology and model aviation to encourage his viewers, customers, and team members to never stop exploring, never stop questioning, and never stop playing.



3DAeroventures' fully 3D-printable, functional RC aircraft designs can be fabricated on hobbyist level desktop 3D printers out of common materials. The digital files of 3DAeroventures' aircraft are available online, with new designs being made available every few months. If you'd like to stay up to date on 3DAeroventures' latest content and designs, visit www.3daeroventures.com and sign up for our email list.

Other ways to connect with 3DAeroventures:

- Consider subscribing to the YouTube channel at www.youtube.com/3daeroventures
- Connect with 3DAeroventures on [Facebook](#) and [Instagram](#)
- Join the Facebook group, [3DAeroventures Pilots Alliance](#), to connect with other Aeroventurers, to share your builds, and to troubleshoot any issues with us and the community.
- With any questions or feedback on 3DAeroventures' designs or content, you can email Eric directly at eric@3daeroventures.com



Never Stop Exploring. Never Stop Questioning. Never Stop Playing.

www.3daeroventures.com

Copyright © 2020, DiFi3D LLC, dba 3DAeroventures All Rights Reserved.

 www.youtube.com/3daeroventures

[Privacy Policy](#)

[Terms & Conditions of Sale](#)